

ILLUSTRATED PARTS DIAGRAM

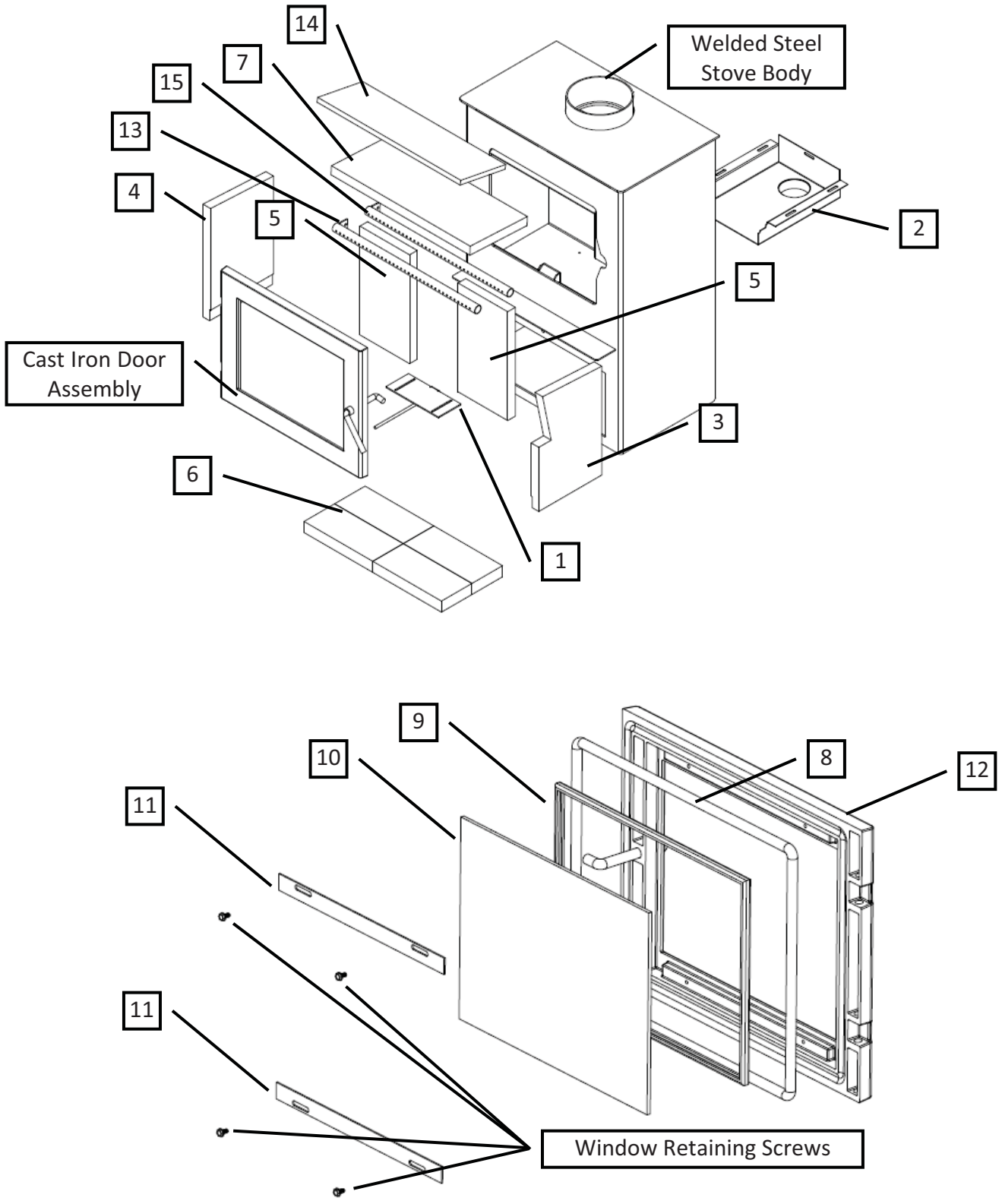

REPLACEMENT PARTS LIST

Diagram No.	Description	Part No.	Per Unit
1	Air Control Slider	AC-17ACS	1
2	Outside Air Adapter	AC-17OAA	1
3	Right Vermiculite Panel	AC-17RBR	1
4	Left Vermiculite Panel	AC-17RBL	1
5	Rear Vermiculite Panel	AC-17RBB	2
6	9" x 4" x 1.25" Firebrick	AC-SB	4
7	Top Vermiculite Baffle	AC-17RBT	1
8	Door Gasket [5/8" dia HD]	AC-DGKNC	1
9	Window Gasket	AC-GGK	1
10	Ceramic Glass Panel	AC-G40	1
11	Window Retaining Brackets	AC-GS16	2
12	Cast Iron Door	CA-16	1
13	Secondary Tube (Front)	AC-17BTF	1
14	Upper Refractory Baffle	AC-17URBVL	1
15	Secondary Tube (Rear)	AC-17BTR	1
Not Shown	Large Spring Handle	AC-SH (Brass)	1
		AC-SHN (Nickel)	
Not Shown	Air Control Spring Handle	AC-SH4 (Brass)	1
		AC-SH4N (Nickel)	

OPTIONAL ACCESSORIES

AC-16 Convection Blower

The Tranquility wood stove was also designed for use with a convection blower for additional heat circulation. The stove is constructed with rear and top convection channels which allow the room air blower to pick up heat from the hottest regions of the stove and transfer it into the home. The mounting screws for the blower are installed into the rear convection channel at the factory; mounting the blower only requires a 5/16" open end or socket wrench to remove these screws and install the blower. When routing the power cord, take care to keep away from hot areas of the unit and remember that this blower is for use only with the stove. Please see the diagram below for clarification on the room air blower installation.

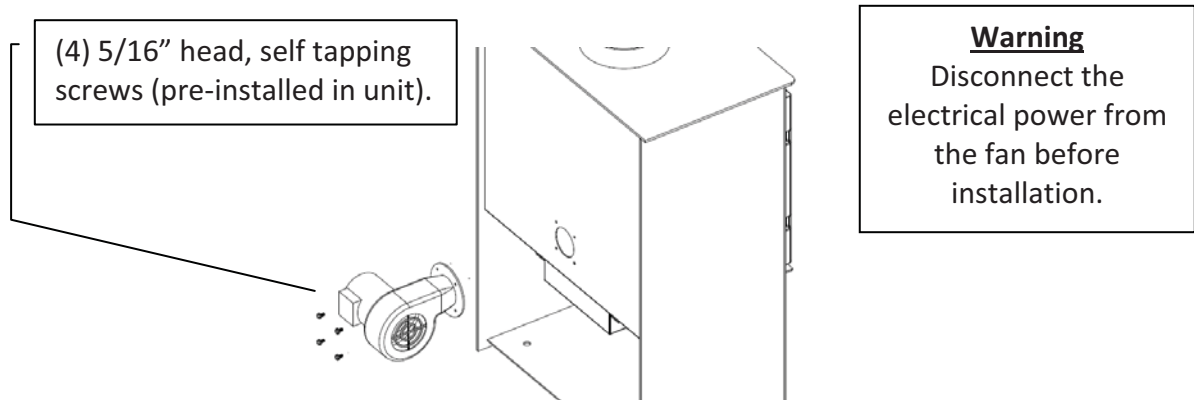

The optional heat circulation blower on this stove requires periodic lubrication; this lubrication should be performed no less than every three months of normal operation. To properly lubricate the blower, use an eye dropper or similar dispensing device to drip 5-7 droplets of SAE 20 oil into the oil port on the side of the blower motor.