

INSTALLATION & OPERATION MANUAL

MODEL NUMBERS: 10-CPM 49-TRCPM 49-SHCPM

*Thank you for purchasing this product from a fine line of heating equipment.
We wish you many years of safe heating pleasure with your new heating appliance.*

Save These Instructions.

IMPORTANT: IF YOU HAVE A PROBLEM WITH THIS UNIT DO NOT RETURN IT TO THE DEALER. CONTACT TECHNICAL SUPPORT @ 1-800-245-6489.

Mobile Home Use:

These freestanding Pellet/Corn/Multi-fuel units are approved for mobile home or doublewide installation with outside combustion air hook-up. See "Flue System" section of manual. Mobile home installation should be in accordance with the Manufactured Home and Safety Standard (HUD), CFR 3280, Part 24.

WARNING: Do Not Install in Sleeping Room.

CAUTION: The structural integrity of the mobile home floor, wall and ceiling/roof must be maintained.

Please Note the Following Precautionary Statements:

NOTE: WE DO NOT RECOMMEND PELLET/CORN/MULTI-FUEL STOVES AS YOUR ONLY SOURCE OF HEAT.

England's Stove Works highly recommends the use of smoke detectors and Carbon Monoxide detectors with any hearth product, including this unit. Follow all manufacturers' instructions when using smoke or Carbon Monoxide detectors.

CAUTION: Please read this entire manual before installation and use of this Pellet/Corn/Multi-fuel burning room heater.



Keep children, furniture, fixtures and all combustibles away from any heating appliance.

WARNING: USE OF OUTSIDE AIR IS MANDATORY WITH THIS UNIT.

DO NOT OPERATE UNIT WITH HOPPER OPEN. LID MUST BE SHUT AND TIGHTLY SECURED.
DO NOT OPERATE WITH DOOR OPEN

SAFETY NOTICE

FAILURE TO FOLLOW THESE INSTRUCTIONS COULD RESULT IN PROPERTY DAMAGE, BODILY INJURY OR EVEN DEATH. FOR YOUR SAFETY AND PROTECTION, FOLLOW ALL THE INSTALLATION INSTRUCTIONS. CONTACT YOUR LOCAL BUILDING OR FIRE OFFICIALS FOR RESTRICTIONS AND INSTALLATION INSPECTION REQUIREMENTS (INCLUDING PERMITS) IN YOUR AREA.

Questions? Need Parts or Options? www.englishstoves.com



Rev. 12/2011

A letter from our Technical Support department:

Thank you for purchasing this fine product from England's Stove Works!

England's Stove Works was started, and is still owned by, a family that believes strongly in a "Do It Yourself" spirit – that's one reason you found this product at your favorite "Do It Yourself" store.

We intentionally design and build our stoves so that any homeowner can maintain his or her unit with basic tools, and we're always more than happy to show you how to do the job as easily and as inexpensively as possible.

From our free, downloadable service sheets; to our detailed Service Videos; to our new "wizard-style," click-through Troubleshooting guide on our web site, we have always tried to help our customers stay "heat-ready," especially while oil and electricity prices continue to skyrocket.

Please look at our vast Help section on our web site and call our Technical Support department at (800) 245-6489 if you need any help with your unit. We are nearly always able to help "walk you through" any repairs, problems or questions you may have.

PLEASE NOTE: While information obtained on our web site and through our 800 number is always free of charge, there will be a service charge incurred with any "on-site" repairs or maintenance that we may arrange.

Wishing you years of efficient, quality and "comfy" heating,

England's Stove Works
Technical Support Department

www.englishstoves.com

(800) 245-6489

<p>IF YOU HAVE A PROBLEM WITH THIS UNIT DO NOT RETURN IT TO THE DEALER. CONTACT TECHNICAL SUPPORT at 1 (800) 245-6489.</p>

IMPORTANT INFORMATION

1. Installation of this Pellet/Corn/Multi-fuel unit should be performed by a professional only. Check local installation codes for your area. Call your Homeowner's Insurance representative for inspection of your stove's installation.
2. Read and comply with the instructions in this manual.
3. This unit should be tested (dry run) for 20 minutes before loading pellets or cherry pits. The stove should automatically shut itself off after the 20-minute dry run. Corn is a 30-minute cycle.
4. **If burning pellets, you should use Premium Pellets, as this stove is designed for Premium Pellets.** Pellets with high ash content will burn dirty and require the unit to be cleaned more often.
5. **If burning corn, you should use corn with less than 14% moisture content.** Corn with high moisture content will burn dirty and require the unit to be cleaned more often.
6. **If burning cherry pits, you should use cherry pits with less than 4% moisture content.** Cherry pits with high moisture content will burn dirty and require the unit to be cleaned more often.
7. Be sure your corn, cherry pits or pellets are not damp or wet. If your fuel is too damp, this stove may not be able to run on the lower Heat Range settings (the fire will die out). Be sure to keep sawdust, debris and fines out of the unit.
8. Use three-inch (3") U.L.-approved CORN VENT TWIST-LOCK PIPE when installing this stove and follow the manufacturer's specifications for installation and clearances (we highly recommend Dura-Vent corn twist-lock pipe – our Part Number **AC-33000**). Even though this pipe interlocks, it is recommended to seal all connections with high temperature silicone (our Part Number **AC-RTV3**) or aluminum duct seal tape. Use at least three screws to secure the pipe to this unit's exhaust blower. Also, if you do not use U.L.-approved twist-lock corn pipe, be sure to use U.L.-approved Corn Vent pipe, and fasten each joint of the pipe with at least three screws.
9. Outside combustion air is mandatory for these units to work properly. Make this connection using a 1 ⁷/₈" I.D. metal pipe (steel, aluminum or copper) and coupler. Be sure to secure the pipe to the unit with a clamp or aluminum tape. The outside end should be covered (screened) to prevent any foreign matter from entering the system. Try to keep the number of bends in this pipe to a minimum. Our Part Number **PU-OAK** (Outside Air Kit with flex pipe) can be used.

NOTE: If the total run of the connection exceeds 6', use 3" metal pipe and coupler instead.
10. Regularly inspect the Burnpot area, remove feeder pot and clean all plugged holes. See Maintenance Section.
11. The ash in the Burnpot should be removed regularly, depending on your burn rate. The area to the right and left of the Burnpot is for ash storage; keep the air holes in the Burnpot clean for a more efficient burn. Check your exhaust system frequently. Refer to "Ash Removal and Disposal" section.

12. Keep corn, pellets and all other combustible materials a safe distance from the unit.
13. This unit will require floor protection if installed on a combustible surface. The minimum floor protector for this unit is 36" x 48" which should give you at least six inches (6") of protection at the rear and at each side, and six inches (6") minimum in the front of the unit.
14. Horizontal runs should not exceed four feet (4') with a maximum vertical flue height of thirty five feet (35'). At fifteen feet (15'), the pipe should be increased to four inch (4") corn vent pipe.
15. This unit should be turned off and allowed to cool prior to cleaning. Any ashes should be kept in an airtight metal container and not disposed of until they are completely cooled.
16. Read the instructions thoroughly, including instructions concerning the digital control board, and save them for future reference.
17. Do not allow paint, chemicals or construction dust on or near your unit. Do not allow liquid or ANY foreign materials on or inside your unit. Shut your unit down and cover it when painting, construction or similar activity is taking place. Wipe and clean your unit after any construction is done in your home, or if any foreign material gets on or inside your unit. You may also need to remove the rear and side cover plates to your unit (unplug unit first) and vacuum and clean the motors and inside of your unit.
18. Improper gasket maintenance, including failure to replace gaskets, can cause air leaks resulting in smoke-backs.
19. Remember that, as with any appliance, there is user responsibility involved, including installation, operation and maintenance of this product. Be sure to check local codes, and call Technical Support at (800) 245-6489 if you have any questions.
20. **Be sure to follow the directions of all manufacturers of third party products that you use, including exhaust pipe, etc. Never apply firestarter products (including gel) to a hot surface or hot coals.**
21. **Basement Installation:** Basement installation should be performed only by a professional installer. For basement installations, a three inch (3") pipe and coupler must be used for Outside Combustion Air, and a minimum clearance of three feet (3') must be maintained from the ground to the corn vent exhaust pipe outside the dwelling. Keep in mind that each elbow used reduces draft by up to 30%; it is good practice to add three feet (3') of vertical rise for each elbow used. Example: After the 2nd elbow used, add six feet (6') of vertical rise before terminating your vent pipe.
22. **DANGER!** Do not open the door on this unit if the Stirrer is still moving! See instructions on "Setting the Stirrer" later in this manual. See Burnpot installation pictures.

IMPORTANT NOTICE:

This unit must be properly installed to prevent the possibility of a house fire or "smoke-back." The instructions must be strictly adhered to.

Do not use makeshift methods or material which may compromise the installation.

Your unit requires periodic maintenance and cleaning (refer to manual). Failure to maintain your unit may lead to a variety of problems, including but not limited to smoke spillage into the home. England's will not be liable for consequential or indirect damages to property or persons resulting from the use of this product.

UNIT PREPARATION

1. Attach the spring handle to the door by turning it counterclockwise. **Important: Also check hopper latch – must be tight so that the top is sealed to prevent back-burn.**
2. Test your 110-volt outlet for current and then plug in the unit. **(Must be a 15A circuit minimum, should be 20A if circuit is GFCI protected. We highly recommend a surge protector for our unit, as the control panel is electronic).**
3. Be sure to “dry run” your unit for 20 minutes before connecting it to the flue. During this time the blowers and auger will operate at different times throughout the 20-minute period (it should stop automatically after 20 minutes; 30 minutes for corn).

Visit our web site at www.englishstoves.com for helpful information, frequently asked questions, parts/accessory orders and more!

IMPORTANT INFORMATION – READ BEFORE OPERATING

- When installing your Pellet/Corn/Multi-fuel stove, particular attention needs to be made in regards to fire protection. If the unit is not properly installed, a house fire may result. For your safety, follow the installation and operation instructions provided, and if a question arises contact local building or fire officials about restrictions and installation requirements in your area.
- Read the Operation and Fuel sections of this manual before plugging in your unit.
- Always unplug the unit before attempting any service work.
- Do not connect the unit to a chimney flue already serving another appliance.
- When installing the chimney pipe to the unit, it is important to remember that the unit operates on negative pressure and the chimney on positive pressure. All chimney connections, elbows, and fittings must be air-tight. **(Proper venting practices must be followed. Consult with a venting professional.)**
- Ashes must be disposed of in a metal container with a tight fitting lid.
- **All** minimum clearances to combustibles **must** be followed.
- **It is important to use fuel that is clean, dry and consistent.** It is recommended that you purchase your entire heating season supply of fuel at one time, to make sure it is the same.
- This unit has been tested with 3 different fuels as of May 2007. Call Technical Support at (800) 245 6489 if you have questions regarding the fuel you are trying to burn.

This stove was tested with:

1. Hardwood Pellets
2. Shelled Corn
3. Cherry Pits

- The Pellet/Corn/Multi-fuel stove is tested for operation with corn with **14% or less** moisture content; it is recommended that corn with **11-12%** moisture be used for most efficient operation of this unit. **Corn with over 12% moisture has a lower BTU value and will be hard to burn on the lower settings.**
- Corn must be clean and free from debris; never burn corn straight from the field. Stalk parts, excessive fines and cob remnants, etc. will clog the auger mechanism. We highly recommend the use of a sifter; sifters to filter your corn are available from dealers (and we offer a sifter at www.englishstoves.com). Damage caused by dirty and/or unfiltered (unsifted) corn is not covered by the product warranty – ask for and use clean filtered bagged corn only.
- **DISCLAIMER NOTICE:** No guarantee is made regarding the heating capacity of this product. The actual area that this unit will heat depends on factors such as building conditions, heat loss, type of construction, amount and type of insulation, type of air movement and heat distribution, and the location of the product.
- **Important:** Your home must be checked to verify that there is no negative pressure that will affect the operation of this appliance.
- **IMPORTANT: DO NOT BURN “TREATED” SEED CORN IN YOUR STOVE.** Seed corn is treated with chemical pesticides that are harmful or fatal if swallowed; therefore, seed corn is dangerous to have in the house, especially where children can reach it. Burning treated seed corn in your stove will void your warranty and will destroy the exhaust system on the unit.
- There are many varieties of corn grown around the world. Each variety has unique characteristics including the shape and size of the kernel. Your stove will burn more consistently with a small to medium kernel corn. If the kernel size of the corn varies greatly or if you switch sources frequently, you will get a less consistent burn. Do not use corn with high wax content.
- Vacuum the hopper out after every 6-8 bags to eliminate buildup of saw dust and fines from corn.
- Your unit was primarily designed to burn pellets, but will also burn dried cherry pits. Make sure your supplier is selling Dried Cherry Pits (preferably with less than 4% moisture content) for use as fuel in pellet burning stoves.
- **IMPORTANT: DO NOT USE CHERRY PITS DESIGNED FOR CRAFTS AND HOBBIES.** This type is usually bleached and/or over dried.

Notes on termination of Vent Pipe (see also “FLUE SYSTEM” section of manual):

1. Not less than three (3) feet above any forced air inlet located within ten (10) feet.
2. Not less than four (4) feet below, four (4) feet horizontally from, or one (1) foot above any door, window or gravity air inlet into any building.
3. Not less than two (2) feet from an adjacent building, and not less than seven (7) feet above grade where located adjacent to public walkways.

The exhaust exit shall be arranged so that the flue gases are not directed so that it will affect people, overheat combustible structures, or enter buildings. Forced draft systems and all parts of induced draft systems under positive pressure during operation shall be installed gastight or to prevent leakage of combustion products into a building. Through-the-wall vents shall not terminate over public walkways, or where condensate or vapor could create hazards or a nuisance.

*Be sure to follow local codes and all manufacturers' instructions (including exhaust pipe).
Consult a professional installer and/or call Technical Support if you have any questions.*

**NOTE: YOUR UNIT MUST BE INSTALLED BY A QUALIFIED
INSTALLER, SUCH AS AN NFI CERTIFIED SPECIALIST**

GUIDELINES FOR EXHAUST VENTING SYSTEMS DESIGN

INSTALL VENT AT CLEARANCES SPECIFIED BY THE VENT MANUFACTURER

- A UL listed three-inch or four-inch (3”or 4”) type “L” corn vent exhaust system must be used for installation and attached to the pipe connector provided on the back of the unit. Use a three-inch to four-inch (3” to 4”) adapter for four-inch (4”) pipe. A cap must be used at the termination of type “L” vent chimneys. Four-inch (4”) type “L” is recommended for elevations above 2,500 feet above sea level.
- Do not terminate vent in any enclosed or semi-enclosed area, such as: carports, garage, attic, crawl space, under a deck or porch, walkway or enclosed area, or any location that could build up a concentration of fumes such as a stairwell, covered breezeway, etc.
- Vent surfaces can get hot enough to cause burns if touched. Non-combustible shielding or guards may be required.
- Do not install a flue damper in the exhaust vent of this unit.
- Termination must exhaust above air inlet elevation. Installation **MUST** include three (3) vertical feet of corn vent pipe. This will create some natural draft to prevent the possibility of smoke or odor during unit shutdown, and keep exhaust from causing a nuisance or hazard from exposing people or shrubs to high temperatures. **DO NOT CONNECT THIS UNIT TO A CHIMNEY FLUE SERVICING ANOTHER APPLIANCE. DO NOT CONNECT DIRECTLY TO A MASONRY CHIMNEY.**
- Distance from doors and windows, gravity or ventilation air inlet into building: not less than four feet (4 ft.) below, four feet (4 ft.) horizontally from, one foot (1 ft.) above (this does not apply if the windows are non-opening or have been fixed so they cannot open).
- Distance from bottom of termination and grade - three feet (3 ft.) minimum. This is conditional upon the plants and nature of the grade surface. The exhaust gases are hot enough to ignite grass, plants, shrubs, etc. located in the vicinity of the termination. The grade must not be a lawn. Distance from bottom of termination and public walkways is seven feet (7 ft.) minimum.

- Distance to combustible materials – three feet (3 ft.). This includes adjacent buildings, fences, protruding parts of the structure, roof overhang, plants and shrubs, etc.
- The installation must include a cleanout tee to enable the collection of fly ash and permit periodic cleaning of the exhaust system. 90° elbows accumulate fly ash and soot, thereby reducing exhaust flow and performance of the unit. Each elbow or tee reduces draft potential by up to 30%.
- Total length of horizontal vent must not exceed 48” (4 ft.). Use three-inch (3”) U.L.-approved CORN VENT TWIST-LOCK PIPE when installing this stove and follow the manufacturer’s specifications for installation and clearances (we highly recommend Dura-Vent corn twist-lock pipe – our Part Number **AC-33000**). Even though this pipe interlocks, it is recommended to seal all connections with high temperature silicone (our Part Number **AC-RTV3**) or aluminum duct seal tape. Use at least three screws to secure the pipe to this unit’s exhaust blower. Also, if you do not use U.L.-approved twist-lock corn pipe, be sure to use U.L.-approved Corn Vent pipe, and fasten each joint of the pipe with at least three screws.
- The “L” vent or corn vent stainless exhaust system must be installed so as to be GAS TIGHT! Follow the vent manufacturer’s installation instructions.
- The area where the vent pipe penetrates the exterior of the home must be sealed with silicone or other means to maintain the vapor barrier between the exterior and the interior of the home.

NOTE: These are guidelines only. Proper venting is accomplished by design and common sense. In most installations, three-inch (3”) diameter venting is adequate. If it does not vent properly, you must change it to four-inch (4”) diameter venting.

DO NOT CONNECT TO ANY AIR DISTRIBUTION DUCT OR SYSTEM.

BURNING SOLID FUELS

Ashes will need to be removed from the unit periodically. See Ash Removal section. You can minimize cleaning required and maximize efficiency by maintaining the proper draft.

This unit has been designed to burn premium pellets, dry shelled corn or dried cherry pits that meet the Association of Pellet Fuel Industry (PFI) standards.

WOOD PELLETS

Be consistent in your choice of wood pellet supplier. Pellets will vary in content and burn characteristics from supplier to supplier.

- Check your pellets for foreign objects. Your stove warranty will not cover any damage caused due to foreign objects in the fuel supply.
- Store your pellets in a dry place to prevent them from absorbing added moisture.
- To decrease sawdust buildup, the hopper will need to be vacuumed out after every 6-8 bags of pellets, or more often if the quality of the pellets is poor. You may need to screen each bag of pellets if the sawdust becomes a problem.
- Wood pellets vary in size and also ash content (from less than 1% to 3% or more). Your unit will burn more efficiently with small to mid-size pellets. Low ash content pellets will allow you to burn the stove longer between cleanings.
- Your unit is designed to burn pellets that are no larger than one-quarter inch (¼") in diameter, and no longer than two and one-half inches (2 ½") long.

CAUTION: DO NOT PLACE SUCH FUELS WITHIN THE SPACE HEATER'S INSTALLATION CLEARANCES OR WITHIN THE SPACE REQUIRED FOR CLEANING AND ASH REMOVAL.

SHELLED CORN

(Dry, preferably with 11-12% moisture content)

Never burn "deer corn" as it frequently contains molasses/sugars. Store your corn supply in a dry place and keep bags or container sealed to prevent your corn from absorbing excess moisture. Test the moisture content regularly to ensure proper dryness.

IMPORTANT: DO NOT BURN "TREATED" SEED CORN IN YOUR STOVE. Seed corn is treated with chemical pesticides that are harmful or fatal if swallowed; therefore, seed corn is dangerous to have in the house, especially where children can reach it. **Burning treated seed corn in your stove will void your warranty and will destroy the exhaust system on the unit.**

CHERRY PITS

(Dry, preferably with less than 4% moisture content)

Your unit was primarily designed to burn pellets, but will also burn dried cherry pits. Make sure your supplier is selling Dried Cherry Pits for use as fuel in pellet burning stoves.

IMPORTANT: DO NOT use cherry pits designed for crafts or hobbies.

This type is usually bleached or over dried.

FLUE SYSTEM

Caution: Follow the pipe manufacturer's installation instructions and directions for passing through combustible walls and ceilings.

Be sure to check local codes in your area.

NOTE: See the installation drawing later in this manual (Illustration 1).

This unit is equipped with a negative draft system that pulls combustion air through the Burnpot and pushes the exhaust air out of the dwelling. If this unit is connected to the flue system other than the way explained in this manual, it will not function properly. For any of these installations, keep in mind that each elbow used reduces draft by up to 30%; it is good practice to add three feet (3') of vertical rise for each elbow used. Example: After the 2nd elbow used, add six feet (6') of vertical rise before terminating your vent pipe.

Corn Vent Pipe

The UL approved corn vent pipe that we recommend is a twist lock system; however, it is still recommended that high temperature silicone (our Part Number **AC-RTV3**) or aluminum duct seal tape be used at each joint. England's Stove Works recommends the use of Dura-Vent® twist-lock pipe (if you use other pipe, consult your local building codes and/or building inspectors, and secure each joint with at least three screws—see "Important Information" section). *Do not* use "B" vent gas pipe or galvanized pipe with this unit. The corn pipe is designed to disassemble for cleaning and should be checked several times during the burning season — corn vent pipe is not furnished with the unit and must be purchased separately. **Do not install a flue damper of any kind in this system, and do not connect this unit to a flue system serving another heating appliance.**

Through the Wall

To vent the unit through the wall, connect the pipe adapter to the exhaust motor adapter. If the exhaust adapter is at least eighteen inches (18") above ground level, a straight section of corn pipe can be used to initially pass through the wall (see Illustration 1). Your dealer or our factory should be able to provide you with a kit that will handle most of this installation, which will include a wall thimble that will allow the proper clearances through a combustible wall. Once outside the structure, a three-inch (3") clearance should be maintained to the outside wall and a clean out tee should be placed on the pipe that extends through the wall. We recommend a minimum of three feet (3') of vertical pipe with a 90-degree turn away from the house. At this point, a one-foot (1') section and horizontal cap will complete the installation (see Illustration 1).

A wall strap should be placed just below the last 90-degree section to make the system more stable. If you live in an area that has heavy snowfall, it is recommended the installation be taller than three feet (3') to get above the snowdrift line.

The same type installation can be used if your stove is below ground level by adding the clean-out section and vertical pipe inside until ground level is reached. However, we recommend basement installation be performed only by a professional installer. For basement installations, a 3" (three inch) pipe and coupler must be used for Outside Combustion Air, and a minimum clearance of three feet (3') must be maintained outside the dwelling from the ground to the Corn Vent Exhaust Pipe.

The through-the-wall installation is the least expensive and simplest installation. In a through-the-wall installation you should be mindful of the snowdrift line, as well as dead grass and leaves. We recommend a three foot (3') minimum vertical rise on the inside or the outside of the dwelling. Never terminate the end vent under a deck, in an alcove, under a window or between two windows.

Call (800) 516-3636 to inquire about the AC-33000 Through-the-Wall Kit or
Visit our web site at www.englishstoves.com for ordering information!

Through the Ceiling

When venting the stove through the ceiling, the pipe is connected the same as through the wall, except the clean out tee is always on the inside of the house, and a 3" adapter is added before the clean-out tee. You must use the proper ceiling support flanges and roof flashing supplied by the pipe manufacturer -- follow the pipe manufacturer's directions and Illustration 1 in this manual. It is important to note that if your vertical runs of pipe are more than fifteen feet (15') at this point, the corn vent pipe should be increased to four inches (4") in diameter. Do not exceed four feet (4') of pipe on a horizontal run, and do attempt to use the least number of elbows in the flue system. If an offset is used it is better to install a 45-degree elbow whenever possible. *Please remember, installing elbows may inhibit your draft by up to 30% per elbow.*

Outside Air (Outside Combustion Air Intake)

Outside air is mandatory for this unit to operate properly. This unit has been designed and tested with this connection, because so many homes are airtight and there is not adequate combustion air available inside the dwelling. The air intake pipe is located on the bottom side of the Burnpot (from the rear) and measures 1 ½" inside diameter (I.D.). The connection can be made with a metal 1 7/8" I.D. coupler and pipe (see "Important Information" section of manual), and should exit through the wall. Be sure to secure the pipe to the unit with a clamp or aluminum tape. The outside end of the pipe should be covered (screened) to prevent foreign matter from entering the system. Our Outside Air Kit (Part Number PU-OAK) can be used. If the unit is located below ground level, you will need to run the pipe up and then outside the dwelling. NOTE: If the total run of the connection exceeds 6', if more than 2 elbows are used, or if a basement installation, use 3" metal pipe (and coupler) instead.

Mobile Home Installation

Secure the heater to the floor using the two holes in the pedestal. If the unit is on a combustible surface, you will need to drill matching holes in the floor protection that you choose (see Floor Protection section). Do not disturb the structural integrity of the home, and be sure the unit is permanently electrically grounded to the chassis of your home. Remember that outside combustion air is mandatory, and not to install the unit in a sleeping room of the home.

Important Notes Concerning Installation:

***IMPROPER INSTALLATION:** The manufacturer will not be held responsible for damage caused by the malfunction of a stove due to improper venting or installation.

Call (800-245-6489) and/or consult a professional installer if you have any questions.

IMPORTANT: Improper hook-up (too much pipe, too many elbows, etc.) will cause the unit not to operate. Call Technical Support (800-245-6489) if you have questions about your hook-up or if your unit will not operate.

IMPORTANT SAFETY NOTE: If the unit or chimney connector pipe "glows" red (or white), the stove is over-fired. This condition could cause a house or chimney fire. Do not operate your unit too hot, or over-firing may result.

Freestanding Pellet/Corn/Multi-fuel Installation

Caution: Follow the pipe manufacturer's installation instructions and directions for passing through combustible walls and ceilings. Check local codes in your area.

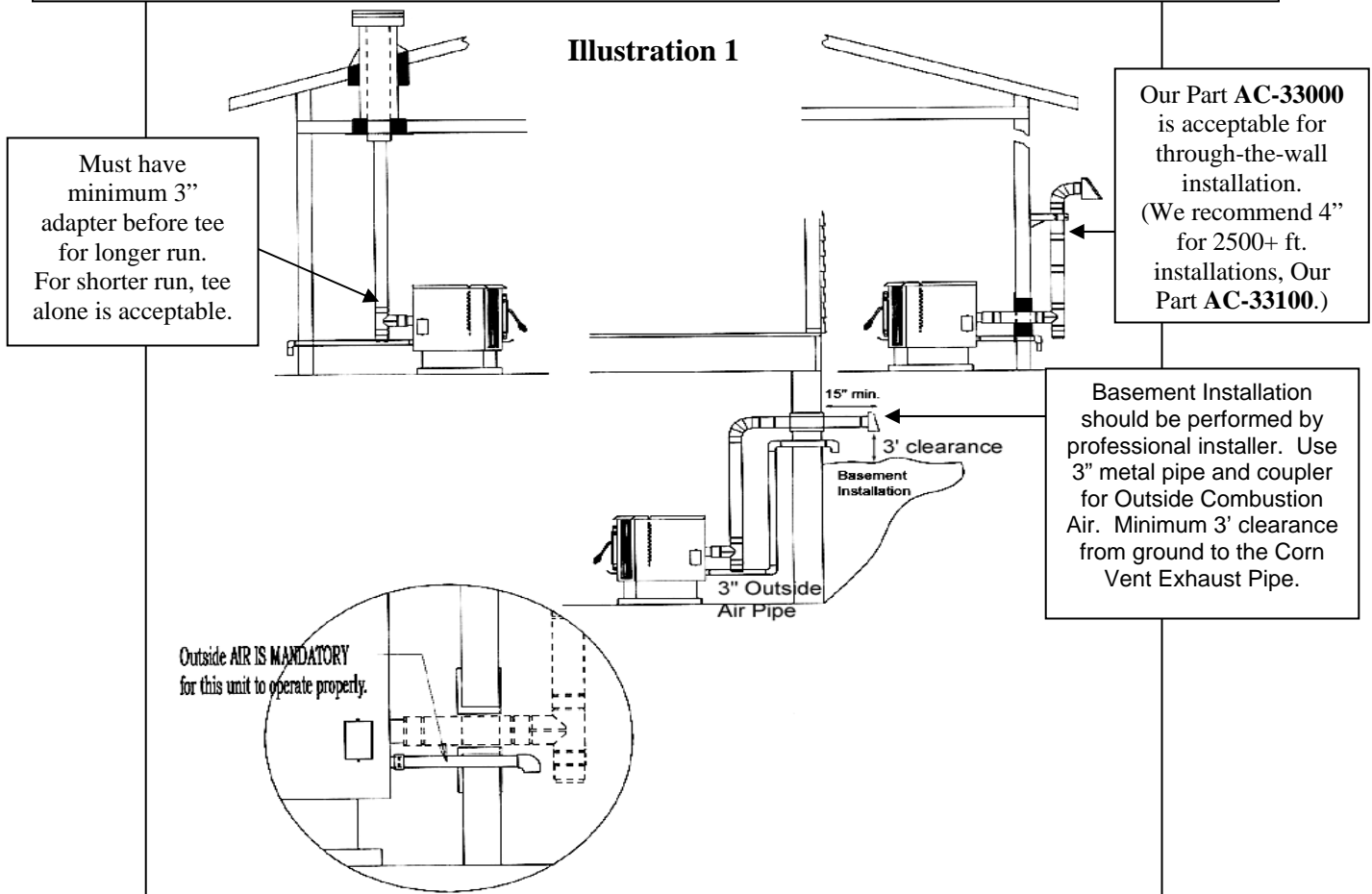

1. If 3" flue pipe exceeds 15' in length, increase to 4" flue pipe for remaining flue connections.
2. Total flue length should not exceed 35'.
3. Horizontal run not to exceed 4'.
4. Floor protector required: Min. size 36" x 48".
5. If the total run of outside air connection exceeds 6', if more than 2 elbows are used, or if a basement install, use 3" metal pipe (and coupler) instead.
6. **Outside Air is mandatory for proper safe operation.**

FLOOR AND WALL PROTECTION

Floor Protection

If your floor is constructed of a non-combustible material such as brick or concrete, there is no need for floor protection. If the floor is constructed of a combustible material such as hardwood, linoleum, or carpet, then you will be required to use floor protection between the unit and the combustible. The protection should be U.L. approved or equal, and should be large enough to provide a minimum of six inches (6") behind and on both sides of the stove. The clearance in front of the stove should be at least six inches (6"). This freestanding pellet unit will need a minimum 36" x 48" floor protector.

Wall Protection

From the rear of this stove only six inches (6") of clearance is required to paneling, wallpaper or drywall (we recommend more clearance for maintenance access). Six inches (6") would be required to a sidewall. From the corner of the stove, 4 1/2" of clearance is required. Alcoves: The alcove must be a minimum of sixty-six inches (66") from floor to ceiling. Six inches (6") of clearance is required from the stove to an alcove sidewall; six inches (6") is required to an alcove back wall.

The corn vent pipe would require the standard three inches (3") clearance, or as recommended by the pipe manufacturer. Normally, additional wall protection is not required with this type unit.

OPERATING INSTRUCTIONS

CAUTION: DO NOT OPERATE WITH THE DOOR OPEN.
Do not burn trash (paper bags, etc.) in this unit.

This stove has an induced draft system and is designed to operate continuously, as frequent shutdown is not required. The setting of the “**Heat Range**” touch pad will control the heat output and the amount of fuel the unit will burn (see “Control Board” section).

NOTE: This stove is using solid fuel and will not restart automatically unless a thermostat is installed. See page 26 – Thermostat instructions.

* **NOTE:** *Blower Speed will automatically be adjusted to the desired Heat Range that you select.*

START- UP PROCEDURES

SETTING THE STIRRER

Warning: Do not open the door on this unit if the Stirrer is still moving!
Bodily Injury can occur!

The Stirrer may be turned Off by pushing the “Air On” button on the bottom of the Control Panel, and then pressing both Down arrows on the “Blower Speed” and “Heat Range” until you see a “0” in the Blower Speed window.

The Stirrer may be turned back On by pressing the “Air On” button on the bottom of the Control Panel, and then pressing both Up arrows on the “Blower Speed” and “Heat Range” until you see a “1” in the Blower Speed window.

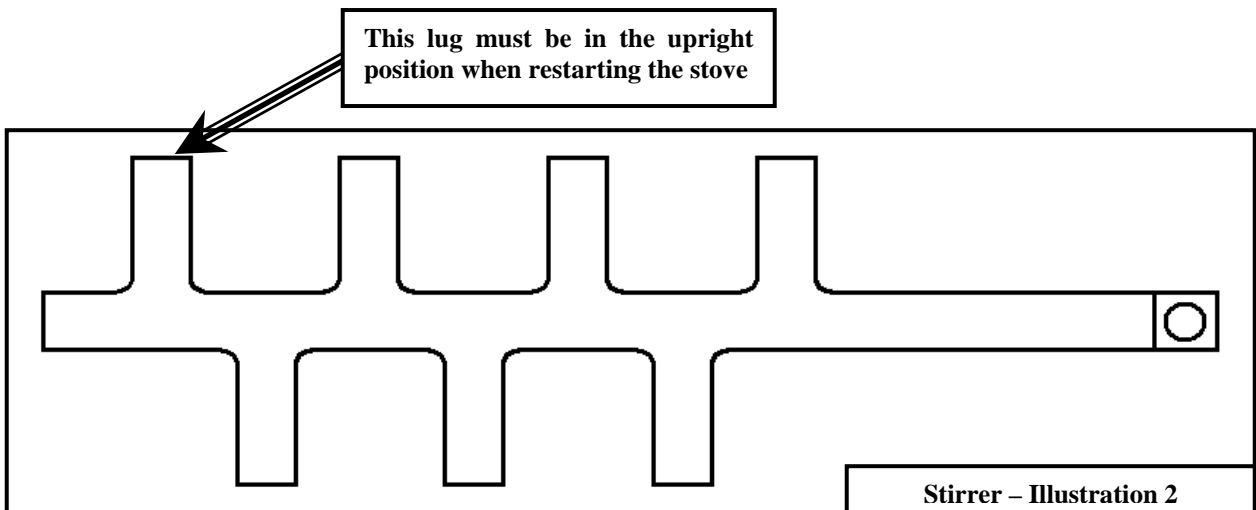

CAUTION: Never use gasoline, lantern fuel, kerosene, charcoal lighter fluid, diesel fuel or any other flammable liquid to start the fire. Keep all combustible materials at a safe distance from stove.

The Heat Range and Blower Speed will automatically be set to setting “5” (default setting during start up) to ensure that proof of fire is detected. During the 20 minute start-up period the user can set the controls to a desired heat setting and *after* the 20 minute start-up the unit will operate at that user setting. When burning corn, start-up period is 30 minutes.

WARNING!

When the “Air On” button on the bottom of the Control Board is pressed, you must make sure you see the number “1” in the Blower Speed window. The Stirrer must be running in the pellet and corn modes (mode 1 – pellet; mode 5 - corn). The Stirrer will stop if you press the “Air On” button and press the Blower Speed and Heat Range arrows down until you see a zero (0) in the window. Before you restart your unit you must see the number “1” in the Blower Speed window. Make sure the Stirrer is turning before you walk away from the unit. The Stirrer will start in 4 minutes in the startup mode. It turns very slowly, so you will want to look to make sure it is actually moving!

NOTE: On the “first fire” (the first time you burn the unit), the Control Panel should be set at a “5” Heat Range and “5” Blower Speed for at least 3 hours to allow the unit to “cure” as the oils from the manufacturing process burn off. Windows and doors in the home should be opened to help ventilate as these oils burn off.

NOTE: If the unit does not start, **DO NOT** try to restart the unit until it has cooled completely down. If the unit does not start or maintain a fire, you will receive an **E-2** in the Heat Range and Blower Speed window of the Control Board. If this occurs, wait until unit has cooled completely down and repeat these steps.

NOTE: The Burnpot and Stirrer is a floating system. This means you will see it rise up and go down. The unit is designed to burn multi-fuel; this feature will allow the unit to run and not hang-up or lock-up on a hard piece of corn, etc. It may make a “jumping” noise when you first start the unit, but it will go away after your unit heats up. **It will not harm the unit.** It is a heavy duty system made with stainless steel, designed to last many trouble-free years.

FUEL NOT FEEDING CORRECTLY

If the fuel is not feeding correctly, the feed auger could possibly be misaligned due to factors such as rough handling during shipping. If you suspect your feed auger is misaligned, call Technical Support at (800) 245-6489.

Automatic Start-Up

When the “ON” button is pressed from a cold start, the unit is in “Start-Up” (after 3 seconds, there will be an “**S U**” in the Heat Range and Blower Speed windows to verify this). While in this mode, the unit has a preset heat range and will remain in this mode for 20 minutes (30 minutes in corn mode) to prevent the unit from over-firing. During this start-up period you can set the Control Board at the setting you desire; after the start-up is complete, the unit will operate at the user setting.

Manually Starting Your Unit

In the event the Auto-Start does not initiate, you may manually start your unit. To manually start your unit, first clean any pellets out of the Burnpot (to prevent over-feeding). Place a handful of new pellets in the Burnpot, then spread a small amount of pellet fire starter over the pellets and ignite them. After the pellets ignite, close the door to your unit and press the “ON” button (if the door is closed before the pellets fully ignite, the Exhaust Blower could put out the fire).

Recommended fire starter materials are: Wax-impregnated wood chips, cardboard cubes or firestarter chips or gel designed for pellet and corn burning stoves. Follow any manufacturer’s directions for these products, and NEVER place any firestarter on any hot surface or hot coals.

CAUTION: **Never use gasoline, lantern fuel, kerosene, charcoal lighter fluid, diesel fuel or any other flammable liquid to start the fire. Keep all combustible materials at a safe distance from stove.**

Wet corn may not start with your auto start igniter. It will help to keep a bag of pellets handy. If your corn does not ignite, shut the unit down, clean out the Burnpot and make sure the unit is not warm. Place a cup full of wood pellets in the in the Burnpot, place a small amount of one of the recommended fire starters (listed above) on the wood pellets and ignite the pellets. Allow the pellets to burn for 1-2 minutes then close the door and push the “ON” button.

CAUTION: **The Firebox should be cool to the touch before attempting to start the unit.**

PELLET START-UP PROCEDURE

If the unit does not start or maintain a fire, you will receive an **E-2** in the Heat Range and Blower Speed window of the Control Board. If this occurs, wait until unit has cooled completely down and repeat.

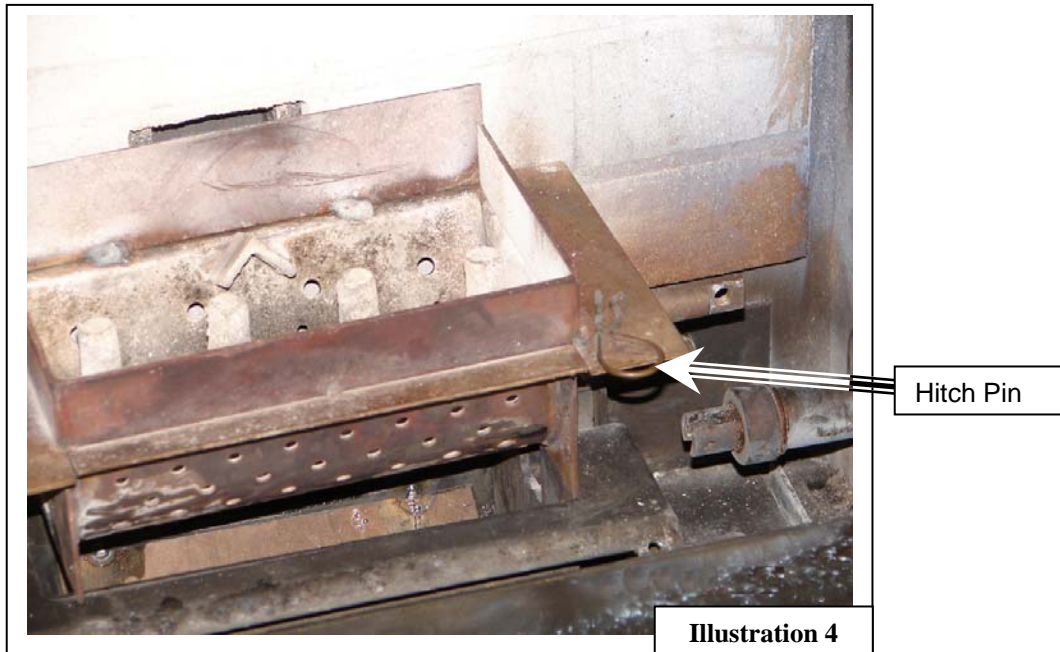

To remove the Stirrer for cleaning

While the unit is **COLD** and the unit is off, press and hold the Air On Temp button until the Stirrer is at the “12:00” position. Pull the hitch pin (marked in Illustration 3). Lifting the Burnpot and Stirrer at the same time, remove the Stirrer from the Burnpot. Clean and clear all holes in the Burnpot and replace Stirrer and Burnpot back into the unit.

NOTE: When replacing the Burnpot, notice there is a welded piece that is always set toward the *back* of the Firebox.

FUEL CHANGE PROCEDURE

When starting the stove with corn, push the “AIR ON TEMP” button and hold, which will rotate the Stirrer mechanism in the Burnpot. Release the button when the 4-prong side of the Stirrer is straight up (in the “12:00” position as shown in Illustration 2, page 13) before following the previous instructions concerning placing the handful of pellets in the Burnpot and starting your fire.

Changing from Pellets to Corn

Your unit was primarily designed to burn pellets, but will also burn corn. Your unit comes ready to burn pellets by default; if you would like to burn corn in your unit, follow the steps below.

WARNING: Do not open the door on this unit if the Stirrer is still moving!
See instructions “Setting the Stirrer” on page 13 in this manual.

NOTE: Before performing these steps make sure the unit is out and completely cold!!

1. The control board must be reset to burn corn. Unplug the unit and plug back in, then press the Blower Speed up and down buttons at the same time and release. You should see a “**1 thru 8**” in the Heat Range window. Push the Heat Range up arrow until you see a “**5**”. Wait for the window to clear. You are now set to burn corn. To change the stove back to burn pellets, Push the Heat Range down arrow until you see a “**1**”. Wait for the window to clear. You are now set to burn pellets.
2. Follow lighting instructions.

Changing from Pellets to Cherry Pits

Your unit was primarily designed to burn pellets, but will also burn dried cherry pits. Make sure your supplier is selling Dried Cherry Pits for use as fuel in pellet burning stoves. Do not use cherry pits designed for crafts or hobbies, as this type is usually bleached or over dried. Your unit comes ready to burn pellets by default; if you would like to burn cherry pits in your unit, follow the steps below.

WARNING: Do not open the door on this unit if the Stirrer is still moving!
See instructions “Setting the Stirrer” on page 13 in this manual.

NOTE: Before performing these steps make sure the unit is out and completely cold!!

1. Remove the Stirrer shaft (**See Illustrations 3 & 4 - Page 15**). Do not use the Stirrer when burning cherry pits.
2. The control board must be reset to burn cherry pits. Unplug the unit and plug back in, then press the Blower Speed up and down buttons at the same time and release. Push the Heat Range up arrow until you see a “**6**”. Wait for the window to clear. Remove the Stirrer (see Illustrations 3 & 4). Set Air On button to “**0**” (see page 14 – first paragraph). You are now set to burn cherry pits. To change the stove back to burn corn, Push the Heat Range down arrow until you see a “**5**”. Wait for the window to clear. You are now set to burn corn. To change the stove back to burn pellets, Push the Heat Range down arrow until you see a “**1**”. Wait for the window to clear. You are now set to burn pellets.
3. Follow lighting instructions.

E-Codes

“E-Codes,” or Error Codes, are codes that will appear in the Heat Range and Blower Speed windows of the Control Board if your unit experiences problems. If you receive these codes, **wait until the unit is cooled completely down before trying to restart your unit.**

If the unit continues to display any E-Code(s), please contact Technical Support at (800) 245-6489 before further attempting to restart your unit.

NOTE: “E-0” indicates “No Error”

E-2 = Fail to Start

E-3 = Unit Overfired

If you see the E-3 code displayed on your control board, you have overfired your unit. You must let the unit cool and clean the Firebox and Burnpot. Be sure to clean the orifices (holes in the Burnpot). You should not burn your unit on High (Heat Range 9) continuously when burning corn. After a couple of hours of burning corn on high, turn the Heat Range to 7 and the Blower Speed to 9. **Running the unit on high, when burning corn for long periods, can damage the unit.**

First Fire: When you push the “ON” button, the Control Board will automatically be set at both “Heat Range” and “Blower Speed” to setting “5”. Allow the stove to burn in this manner for *at least* three (3) hours. This will allow the unit to “cure out” as the paint and the oils from the manufacturing process burn off. We recommend you open doors and windows in your dwelling during this process.

NOTE: Please be patient, your unit has a large Burnpot and it takes a while to equalize (reach maximum heat levels). Do not be concerned by the size of the flame, as this unit gets much hotter than the flame appears. Use gloves when filling the hopper. If you leave the hopper open too long, the stove will shut down.

Subsequent Cold Starts: In a cold start situation, the unit should be operated at a “5” setting until the room air blower begins to operate.

NOTE: Press the “ON” button only once on start-up Except when the hopper is empty (when you run out of fuel or your first fire), press and hold the “ON” button for 10 seconds to purge the unit.. **Pressing the “ON” button a second time during the start-up cycle will cause the start-up cycle to begin again.**

IMPORTANT: If the unit fails to start properly, or does not properly complete the Shut-Down procedure, **open the closest outside door and a window to eliminate the home’s natural draft BEFORE opening the stove’s door or hopper lid.** This will allow any smoke to exit through the external air hook-up instead of spilling into the home.

SHUT-DOWN PROCEDURE

WARNING: NEVER SHUT DOWN THIS UNIT BY UNPLUGGING IT FROM THE POWER SOURCE.

Refer to the following instructions:

Press the "OFF" touch pad to put the stove in the "Shut-Down" mode. There will be an "S D" in the Heat Range and Blower Speed windows while the unit is shutting down to verify this. At this time the red light above the "OFF" pad will illuminate. When the "OFF" pad is touched the auger will instantly stop feeding fuel to the auger tube, but the room air blower, exhaust blower and Stirrer will continue to operate. When the internal temperature drops to 95 degrees the room air blower will cease to operate, and when the internal temperature drops to 90 degrees the exhaust blower will stop. The red light will then shut off and the entire stove will be shut down. The hotter the unit is operating, the longer it will take for the stove to complete the Shut-Down cycle.

Note: The unit will exit the Shut-Down cycle if you press the "ON" button during Shut-Down.

NOTE: If your unit overheats, the auger will stop feeding, "E3" will be displayed on the control board and the unit will go into Shut-Down. If this happens you need to wait 45 minutes before trying to re-light the unit.

If you have any questions or problems contact the Technical Support Department:

Technical Support Department service@englanderstoves.com

P.O. Box 206

Parts Orders ONLY: 800-516-3636

Monroe, VA 24574

Questions: 800-245-6489

(Fax: 434-929-4810)

You may also order parts and options, view frequently asked questions and more, on our

Web Site: www.englanderstoves.com

DAILY OPERATION

Refueling the Unit

Always press the “OFF” touch pad before refueling. The hopper on this stove holds approximately an 50-lb. (wood pellets), and should be refilled when the hopper level drops to three or four inches.

Note: The hopper lid will be warm; therefore, you should always use some type of hand protection. NEVER place your hand near the auger while the stove is operating.

Note: Always ensure that all corn and pellet matter is cleared from the hopper lid gasket before closing. Be sure to close and latch hopper **securely** before re-firing. Do not operate this unit with the hopper lid open or unsecured.

Power Outage

If the power to the unit is interrupted for approximately three minutes or less, the unit will resume operation when power is restored according to the following table:

Unit's State Before Power Loss	State When Power Returns
ON	Start-Up
Start-Up	Start-Up
Shut-Down	Shut-Down
OFF	OFF

If the power is interrupted for more than (approximately) three minutes, the unit will be “OFF” when power returns.

Important: **Do NOT open the hopper lid or the door to the unit during power outage. Open the closest outside door and a window to eliminate the home's natural draft.** Wait for power to be restored and then press the “ON” button to re-start the unit, if necessary.

NOTE: Remember:

- 1) It is **very** important for the unit to be vented properly (see instructions on Outside Air), as the natural draft is needed to clear the smoke from the stove.
- 2) Do **not** open the hopper lid (or the unit's door). This may cause fire to burn in the hopper.

Fuel Outage

If your unit runs out of fuel, let the unit go through the complete Shut-Down cycle and then follow the instructions for restarting the unit.

NOTE: DO NOT TRY TO RESTART THE UNIT HOT. If the unit runs without pellets or corn, after one hour the unit will shut down.

Combustion Blower Failure

If the Combustion (exhaust) Blower should fail on this unit, a Vacuum Shut-Down Switch will automatically stop the auger. This will cause your stove to stop feeding fuel to the Burnpot, and the unit will eventually stop completely. Check your power supply, including tripped breakers, etc. If the blower has failed, you will need to contact Technical Support at (800) 245-6489.

NOTE: It is **very** important for the unit to be vented properly (see instructions on Outside Air), as the natural draft is needed to clear the smoke from the stove.

ASH REMOVAL AND DISPOSAL

IMPORTANT: While the amount of ash generated by this unit is not excessive compared to log-burning woodstoves, keeping the unit clean and free of ash is essential for peak performance. Too much ash build-up hampers airflow and reduces the unit's efficiency, and can cause smoke-back.

Daily Ash Maintenance

Press the "OFF" touch pad and allow the stove to shutdown (approx. five (5) minutes) prior to opening the door. A long-handled screwdriver or long-handled putty knife can be used to scrape off any build-up or crust in the Burnpot area. **Remove and clean the Burnpot (See page 15).** Daily cleaning may not be required when burning wood pellets.

Ash Pan

NOTE: The ash pan must be locked in place when the unit is in operation.

NEVER operate the unit with the ash pan out! This unit has an ash pan for more convenient and hassle-free cleaning; to open, lift up on the handle, then pull the ash pan forward.

NOTE: There are two handles just above the ash pan. These control two access panels (one on each side) inside the unit, in the bottom, to put ashes into the ash pan. Pull the handles toward you to open the panels, push the ashes into the ash pan and then replace them, making sure that the area under each plate is clear before closing it. The unit should be off and cooled before any ash maintenance.

Semi-Weekly Ash Removal

Twice each week: Shut the unit down by pressing the "OFF" pad and allowing the unit to go through the complete Shut-Down cycle. Allow the unit to completely cool down and then remove the ashes. The ashes should be placed in a non-combustible container with an airtight lid and should always be placed on a non-combustible surface or on the ground until completely cooled and free of hot cinders. Once the ash is removed, the Burnpot should be given a thorough inspection. **Remove and clean the Burnpot (See page 15).** Check for any build-up in the front of the burn area. Clean out all air holes, these air holes should be kept clean, as they supply combustion air under and around the fuel. The Cradle assembly (in which Burnpot rests) should also be thoroughly cleaned.

IMPORTANT: Ash build-up can cause the unit to malfunction.

Monthly Ash Removal

Use a screwdriver or chisel and break any creosote build-up in the front of the unit, where the pellets are fed into the Burnpot from the Auger Tube. Also inspect your flue pipes, and remove ash buildup from the clean-out tee.

Annual Cleaning

The stove and the flue system should be given a complete cleaning at the end of the heating season. Remove the Burnpot (**See page 15**), clean it thoroughly, and re-install it. In addition to the cleaning mentioned for semi-weekly and monthly, the Combustion (exhaust) Blower should be removed annually and the blower tube vacuumed of any ash build-up. When cleaning or replacing the blower a new gasket (Part # PU-CBG) should be added between the blower flange and the steel exhaust tube. See video for cleaning tips!

Soot and Fly ash: Formation and Need for Removal – The products of combustion will contain small particles of fly ash. The fly ash will collect in the exhaust venting system and restrict the flow of flue gases. Incomplete combustion, such as occurs during startup, shutdown, or incorrect operation of the room heater will lead to some soot formation which will collect in the exhaust venting system. The exhaust venting system should be inspected at least once every year to determine if cleaning is necessary.

MAINTENANCE

CAUTION: UNPLUG THE UNIT PRIOR TO ANY SERVICE WORK!

SEE EXPLODED DIAGRAM (ILLUSTRATION 8) FOR PARTS REFERENCE

Note: To do any service on this unit the rear access sheet metal panel must be moved back from the stove to allow access. One (1) screw holds this panel to the rear of the stove. To remove the panel you must remove the cover plates on the exhaust and intake pipes (6 screws).

Parts Orders: (800) 516-3636 www.englishstoves.com Questions: (800) 245-6489

Visit our web site for information that details and illustrates the following maintenance tasks.

Auger Motor

The Auger Motor and gearbox are one complete assembly (Part # **CU-047042**), and can be removed by disconnecting the power leads and loosening the two $\frac{1}{8}$ " Allen set screws in front of the assembly. Once the set screws are loosened, the entire assembly will slide from the auger tube.

NOTE: The hopper must be emptied and all pellets removed from the auger **before** removing.

Convection Blower

The Convection (room air) Blower (Part # **PU-4C447**) can be removed by disconnecting the power leads and removing the four mounting screws. Once this is done, the blower will slide out of the stove. This procedure can be reversed to install a new blower.

Combustion Blower

To clean or replace the Combustion (exhaust) Blower (Part # **PU-076002B**), the power leads from the blower and the corn vent pipe must be disconnected. Next, remove the screws that hold the blower to the steel exhaust tube and slide the blower from the stove. The blower impeller, blower tube and steel blower exhaust tube on the unit should be brushed and vacuumed. When cleaning or replacing the blower a new gasket (Part # **PU-CBG**) should be added between the blower flange and the steel exhaust tube.

Vacuum Switch

This unit is equipped with a Vacuum Shutdown Switch (Part # **CU-VS**), which helps control various functions of the unit. If an operational error occurs in the unit, a switch will stop the feed auger. Situations which could cause this include power failure, Combustion Blower failure, improper flue installation, a blocked flue (from rodents, nests, etc.), or "dirty burning" from burning improper fuel (see "Important Information" at the beginning of the manual).

Igniter

This unit has an auto start igniter (Part # **CPM-CH**) which starts by pushing the "ON" button on the control board. If you use dry pellets or corn you should not have a problem with the igniter. If you think the igniter is bad, see page 14 "Manually Starting Your Unit" and call Technical Support.

Note: Corn that is above 12% moisture content may not auto start.
You will need to manually start your unit.

Replacing the Stirrer Drive Motor

1. Locate the access panel on the right side (looking from front of stove).
2. Remove the four (4) $\frac{5}{16}$ " mounting screws.
3. Locate the drive motor mounting bracket which is secured by two (2) $\frac{1}{2}$ " bolts (C). Loosen these bolts.
4. Locate the $\frac{1}{2}$ " chain adjustment bolt (A) on the left side of the drive motor. Loosen this bolt.
5. Remove the two (2) $\frac{1}{2}$ " mounting bolts (C).
6. Slide drive motor mounting bracket toward the front of the stove and remove chain from sprocket (B).
7. Remove bracket and motor through access panel and disconnect the two power leads from motor.

Removing Motor and Sprocket

1. Remove $\frac{1}{2}$ " chain adjustment bolt (A).
2. Locate the $\frac{3}{32}$ " Allen Head setscrew on the sprocket and loosen.
3. Remove sprocket (B) from motor shaft.
4. Remove the four (4) drive motor mounting screws (D) with a $\frac{5}{16}$ " nutdriver or socket.

NOTE: When re-installing the sprocket, align the $\frac{3}{32}$ " Allen Head setscrew with the flat side of the motor shaft.

Replacing the Stirrer Drive Shaft

1. Remove cast plug from right side (looking from the front of the stove) using a $\frac{3}{16}$ " Allen Wrench.
 2. Locate the access panel on the right side looking from front of stove.
 3. Remove the four (4) $\frac{5}{16}$ " mounting screws (D).
 4. Locate the drive motor mounting bracket which is secured by two (2) $\frac{1}{2}$ " bolts (C). Loosen these bolts.
 5. Locate the $\frac{1}{2}$ " chain adjustment bolt (A) on the left side of the drive motor. Loosen this bolt.
 6. Remove chain from Stirrer Shaft sprocket (B).
- NOTE: It may be necessary to rotate the shaft by hand to access the set screw.
7. Locate the $\frac{3}{32}$ " Allen Head setscrew on the sprocket and loosen.
 8. Remove $\frac{5}{8}$ " locking collar from Stirrer shaft inside the unit using a $\frac{5}{32}$ " Allen Wrench.
 9. Remove shaft by pulling to you from outside the stove.

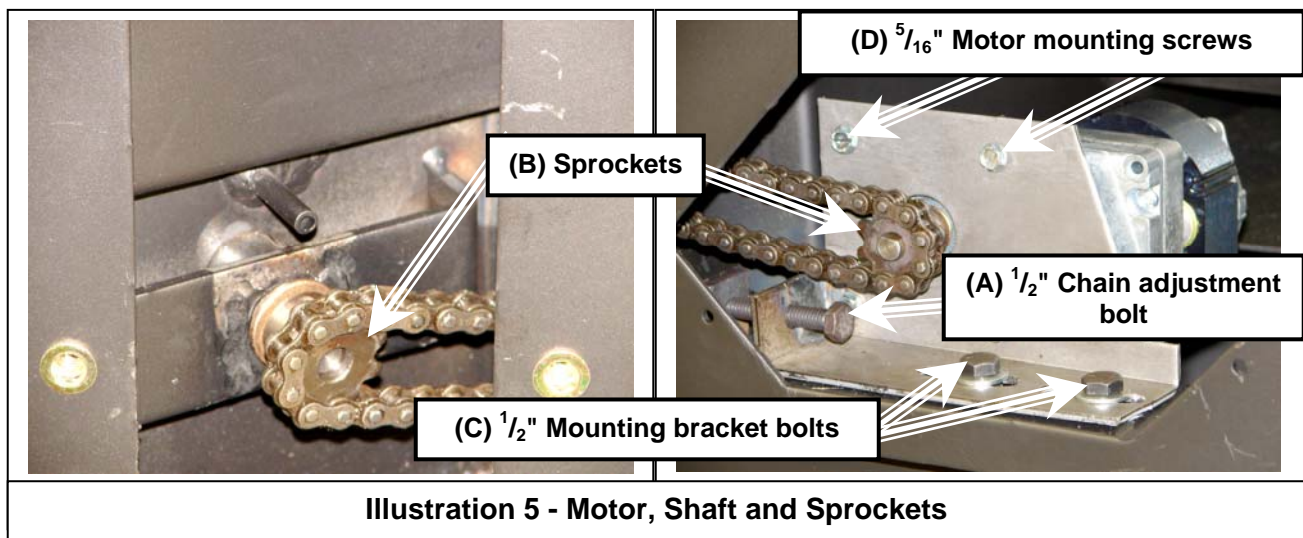

Gaskets

IMPORTANT: IMPROPER GASKET MAINTENANCE, INCLUDING FAILURE TO REPLACE GASKETS, CAN CAUSE AIR LEAKS RESULTING IN SMOKE-BACKS.

This unit comes with a $\frac{1}{2}$ " rope gasket around the door that should be replaced at least every two years. To replace the *door gasket* (Part # **AC-DGKCPM**), the old gasket must first be removed entirely — prior to adding the new adhesive, you may have to scrape the old cement from the door channel. Once the cement and gasket have been added, the door should be closed and latched for twenty-four hours to allow the cement to harden.

If you are replacing the *window gasket* (Part # **AC-GGK**), the new gasket will already have adhesive on one side. Remove the paper on the adhesive side and place the gasket around the outside edge of the glass, centered over the edge. Fold the gasket edges over on the glass forming a "U" shape. You should also replace the *Combustion Blower gasket* (Part # **PU-CBG**) whenever you remove or clean the Combustion Blower.

Finish

This new unit has been painted with High-Temperature Paint that should retain its original look for years. If the unit should get wet and rust spots appear, the spots can be sanded with plain steel wool and repainted. We recommend High-Temperature Spray Paint (Part # **AC-MBSP**), as others may not adhere to the surface or withstand the high temperatures.

Glass

This unit has a ceramic glass (Part # **AC-G20**, comes with gasket) in the viewing door. Surface scratches are acceptable, but if this glass becomes cracked in any area, the unit should be shut down and the window replaced with this high-temperature ceramic glass.

If you have any questions or problems contact the Technical Support Department:

Technical Support Department service@englanderstoves.com

P.O. Box 206

Parts Orders ONLY: 800-516-3636

Monroe, VA 24574

Questions: 800-245-6489

(Fax: 434-929-4810)

You may also order parts and options, view frequently asked questions and more, on our

Web Site: www.englanderstoves.com

Control Board

The Control Board (Part # **CPM-CB07**) is a digital read-out board. This board offers a wide variety of settings to operate the unit. This part can be removed from the unit by loosening the two outside screws and pulling the board back to the inside of the stove. The rear access panel should be removed prior to removing the control board. A 6-amp “quick-blow” fuse is used on this Control Board.

NOTE: The bottom three control buttons are preset at the factory and should *not* require any changes. See “Operating Instructions” and “Daily Operation” section of the manual for instructions on other Control Board settings.

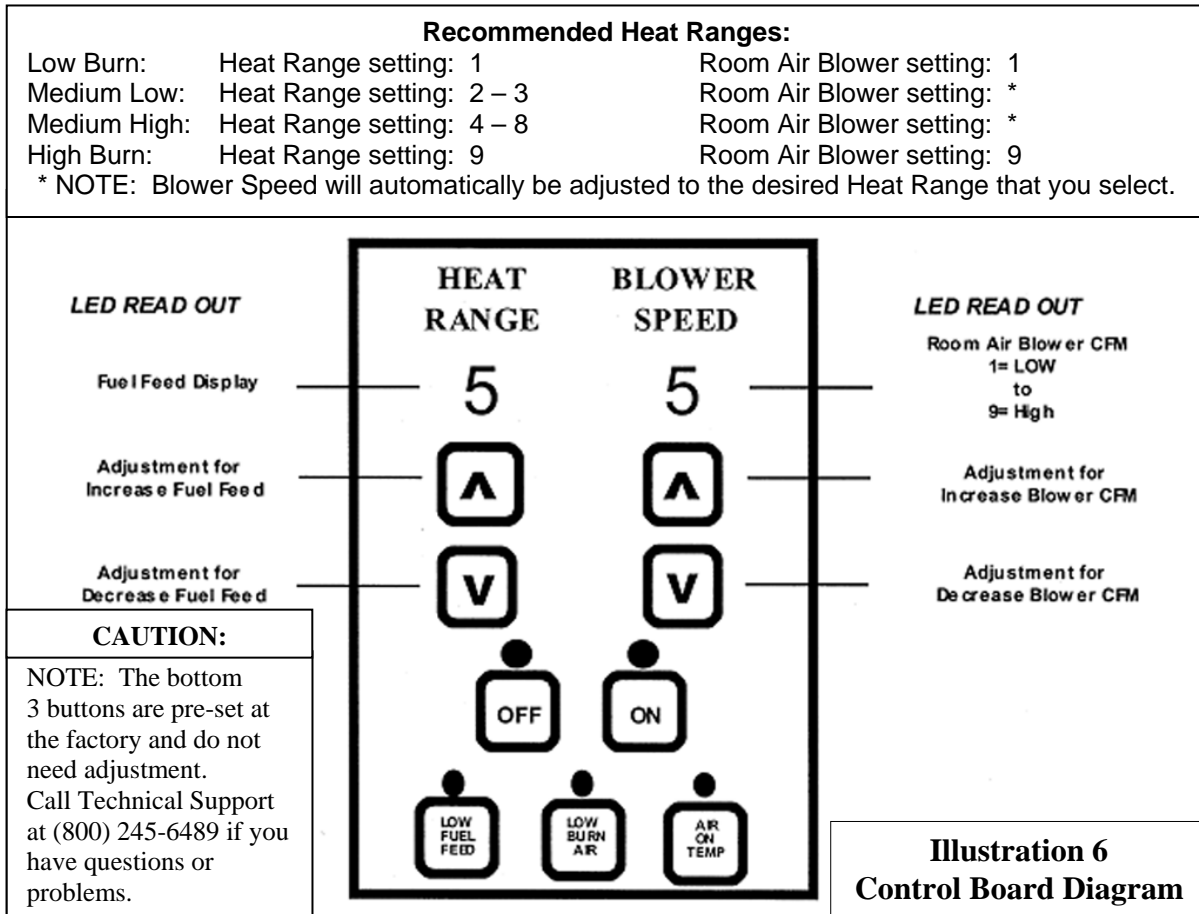

CAUTION: Moving Parts May Cause Injury.
Do NOT Operate with Panel(s) Off.

DANGER: Parts May Be Hot. Risk of Electric Shock.
Disconnect Power Before Servicing Unit.

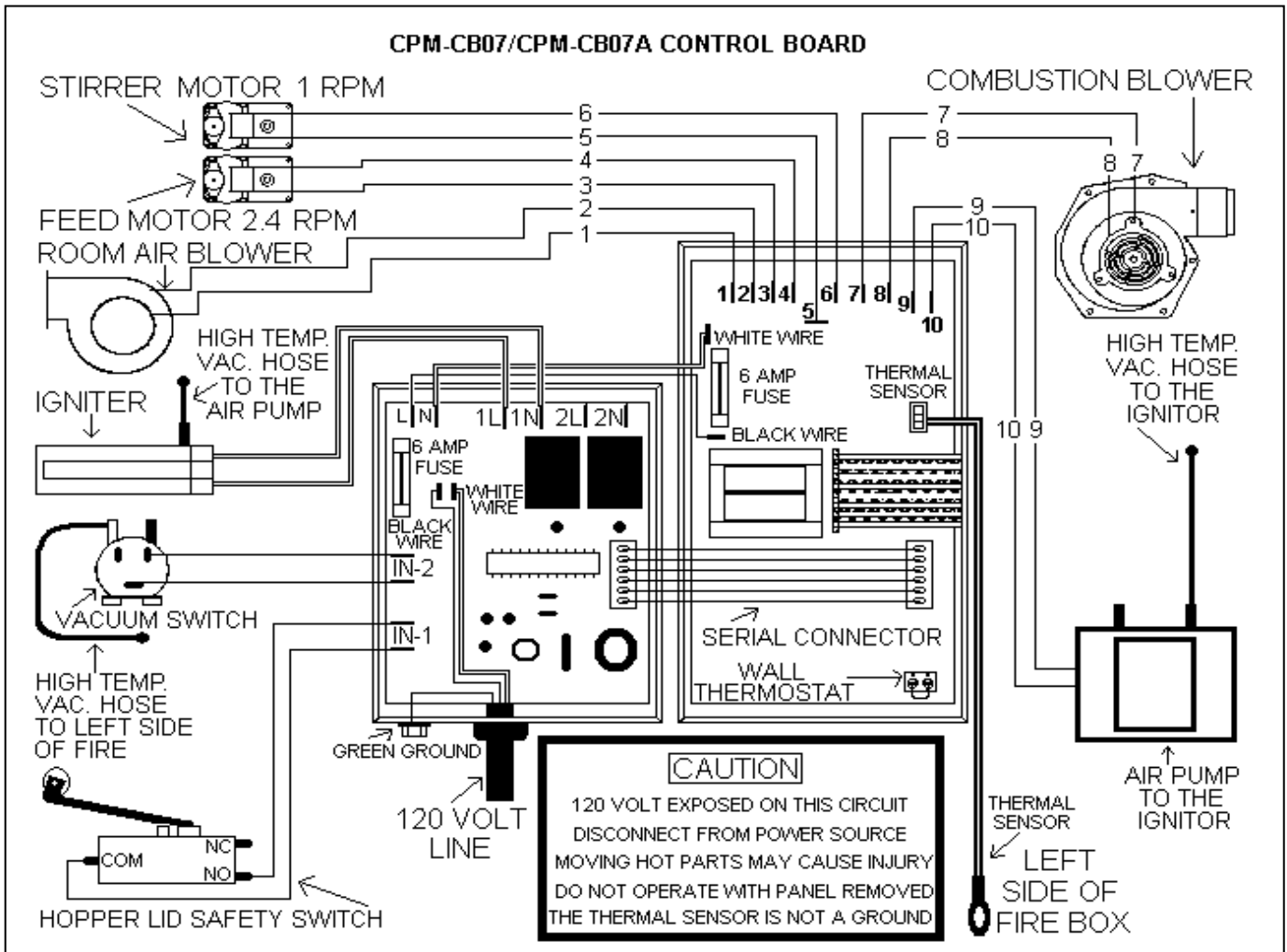

CIRCUIT BOARD FUNCTIONS

COMPONENT	OPERATION START	OPERATION END
Exhaust Blower (Combustion)	Starts Immediately.	Will continue until shutdown. Shutdown will occur when the operating temperature is below 90 degrees.
Stirrer	Three minutes after starting, the Stirrer will begin to turn.	Will continue intermittently, as determined by the Heat Setting, until Shutdown
Auger	When starting, the auger will begin to turn.	The auger will continue at the feed rate determined by the Heat Setting. NOTE: Safety switch, Hi Limit and Vacuum Sensor must be activated to continue proper operation.
Room Fan (Convection)	Begins when 110 degrees is reached.	Will continue to operate until the unit cools down to below 90 degrees. This may take from several minutes up to an hour.
Automatic Shutdown	If, after 15 minutes, the unit has not reached the preset operating temperature, the unit will begin to automatically shut down. This will be evidenced by the red light on the Control Board.	If the timer should expire before the preset operating temperature is achieved, resetting the timer is possible by switching the Control Board "OFF" and then back "ON."
Normal Operation	If, after 15 minutes, the preset operating temperature of 110 degrees is achieved, normal operation will continue.	Operation will continue until either the Control Board is turned "OFF," or the operating temperature falls to below 90 degrees. At this time, the unit will default to "Automatic Shutdown."

ACCESSORY ITEMS

The following accessories can be added to your unit at anytime after purchase; however, let the unit cool down before adding any accessories.

Thermostat

An external thermostat (such as our Part # **PU-DTSTAT** (wall) or Part # **AC-3003** (remote)) can be used on our Pellet/Corn/Multi-fuel units as long as it is a low-voltage that works with millivolt systems. After unplugging the unit, locate the jumper wire (J-18) on the bottom of the control panel. The two screws should then be loosened and the jumper wire removed from the board. Next, the two thermostat lead wires should be slipped into these openings and the screws tightened; the jumper wire should be saved for future operation without a thermostat.

THERMOSTAT OPERATION: This stove is equipped with a unique, new feature that allows two options for thermostatic operation: The stove comes from the factory pre-programmed in "On/Off mode," which turns the stove on and off when the call for heat comes or leaves, like a furnace. The second, or "High/Low mode," burns at whichever heat range you set the stove at until the call for heat leaves, at which point the stove goes to the Low heat range setting.

To set the stove in the "High/Low mode," unplug the unit and plug it back in, then press and hold both down arrows until H L appears in the heat range and blower speed windows. The unit is now in "High/Low mode." (Note: Repeat this to change back to "On/Off mode;" a 0 0 will appear in the heat range and blower speed windows). Using a thermostat in On/Off mode may shorten the life of your stove's igniter.

Please note: Certain units may not respond to this; if your unit does not respond in this manner please contact Technical Support at (800) 245-6489.

AC-109, AC-109BN Lip Trim

There is one piece of J-Channel trim that snaps onto the ash apron. Remove the protective covering from the trim and force the piece onto the edge. Although it should stay in place, stove cement can be used to secure it if necessary.

ACCESSORIES AND OPTIONS

<u>PART NUMBER</u>	<u>PART DESCRIPTION</u>
PU-OAK	Outside Air Kit (Now included with unit!)
AC-33000	3" Corn Vent Kit (Through-the-Wall)
AC-33100	4" Corn Vent Kit (Through-the-Wall)
PU-DTSTAT	Wall Thermostat
AC-3003	Remote Thermostat
AC-109	Brass Lip Trim
AC-109BN	Brushed Nickel Lip Trim
AC-MBSP	High Temp. Spray Paint

Replacement Parts, Accessories and Options can be ordered from the factory at:
(Parts orders ONLY) -- **(800) 516-3636**, or on our web site: www.englishstoves.com .

If you have any questions or problems contact the Technical Support Department:

Technical Support Department service@englishstoves.com
P.O. Box 206 **Parts Orders ONLY: 800-516-3636**
Monroe, VA 24574 **Questions: 800-245-6489** **(Fax: 434-929-4810)**

You may also order parts and options, view frequently asked questions and more, on our
Web Site: www.englishstoves.com

REPLACEMENT PARTS

<u>ITEM</u>	<u>PART NUMBER</u>	<u>PART DESCRIPTION</u>
1	CA-10	Door
2	AC-G20	Glass with Gasket H 11.5 X W 14.75
3	AC-GGK	Glass Gasket Kit
4	AC-GSCPM	Glass Supports
5	CA-11	Side Panel Castings
6	CA-DH	Cast Door Handle
7	CPM-CFB	Brick Fiber board
8	CPM-BP	Burnpot
9	CPM-FS	Fuel Stirrer
10	CPM-MC	Fuel Stirrer Collar ⁵ / ₈ "
11	CA-CPMDS	Fuel Stirrer Drive Shaft
12	R-FN-HP	Fuel Stirrer Hitch Pin
13	CPM-FST	Fuel Stirrer Tube 3"
14	R-FN-SF-2024-16	Fuel Stirrer Bushings - 1" (2 each)
15	CPM-26CH	Fuel Stirrer Drive Chain
16	CPM-SP	Fuel Stirrer Sprocket (2 each)
17	CPM-SMB	Stirrer Motor Bracket
18	PU-AFUF	Auger
19	CPM-RCP	Right Side Cover Plate
20	PU-047040	1 RPM Stirrer Motor
21	CPM-CB07	Control Board
22	CPM-CB07A	Aux Corn Control Board
23	CU-VS	Vacuum Switch
24	PU-VH	Vacuum Hose
25	AC-APCPM	Ash Pan
26	AC-03	Ash Pan Knob
27	CPM-BR (L or E)	Base & Riser
28	PU-CBG	Exhaust Blower Gasket
29	PU-076002S	CPM Exhaust Blower
30	CPM-LCP	Left Side Cover plate
31	CA-ATUF	Auger Tube Assembly
32	PU-ATGUF	Auger Tube Gasket
33	CU-047042	2 RPM Auger Motor
34	PU-4C447	Convection Air Blower
35	PU-HFGUF	Hopper Flange Gasket
36	CPM-RAP	Rear Access Panel
37	CPM-HOP	Hopper
38	AC-GGK	Hopper Lid Gasket
39	CPM-HL	Hopper Lid
40	PU-62-40-151-3	Hopper Lid Latch
41	CA-AMPP	Auger Mounting Plate
42	CA-AC	Auger Coupler
43	AC-HLSB	Hopper lid Switch
44	PU-CH6	Igniter
45	PU-HLG	Hopper Top Gasket
46	CPM-PGB52	Insulation Exhaust Tube Gasket
47	AC-SHN	Brushed Nickel Spring Handle (not shown)
48	AC-SH	Brass Spring Handle (not shown)
49	AC-DGKCPM	Door Gasket (not shown)
50	PU-GP	Guide Plate (not shown)
51	CU-RG	Rubber Gasket (not shown)
52	CPM-APG	Ash Pan Gasket (not shown)
53	CPM-AP	Air Pump (not shown)

(See Item numbers on Exploded Diagram for part location)

10-CPM Exploded Diagram for Part Location

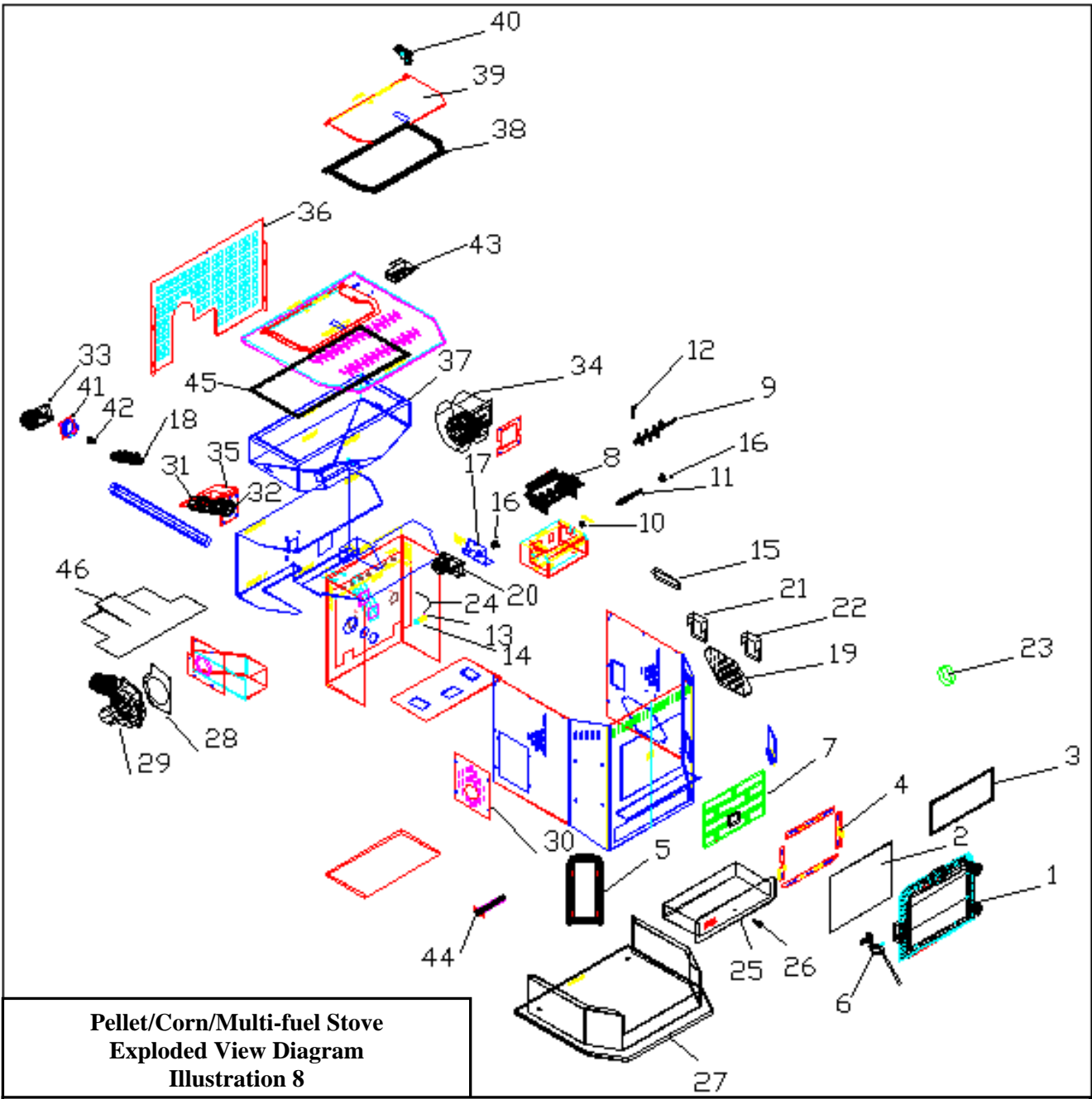

Dimensions of your corn/pellet/multi fuel unit:

28"W x 33"H x 28"D

385 lbs.

(Approx. 18" height from floor to center of exhaust)

CAUTION: UNPLUG THE UNIT PRIOR TO ANY SERVICE WORK!

Adjusting your Hopper Lid Latch

The seals around the top of the pellet hopper are important to safe and efficient operation of the unit. The latch installed on these units is designed to pull the hopper lid tight against this seal. Over the course of operation as these seals “wear in” and compress, the tension of the latch should be tested periodically, and adjusted if necessary.

To adjust the lid latch, the following tools will be needed; two ½ inch wrenches, or a ½ inch wrench and a ½ inch socket.

In order to adjust the latch, first open the hopper lid and then lock the latch in its closed position. Then take the ½ inch wrench and loosen the nut closest to the latch. This nut is then adjusted closer to the lid itself to tighten the latch. After adjusting this nut to the desired location, hold this nut in place with the ½ inch wrench, the tighten down the holding nut on the end of the latch shaft with the ½ inch socket or second wrench to hold the latching assembly in place

After tightening the latch, test the latch for proper tension by locking the lid down and lifting each front corner of the lid. The lid should be firmly held down by the latch. Repeat the same procedure if the latch is still not tight enough.

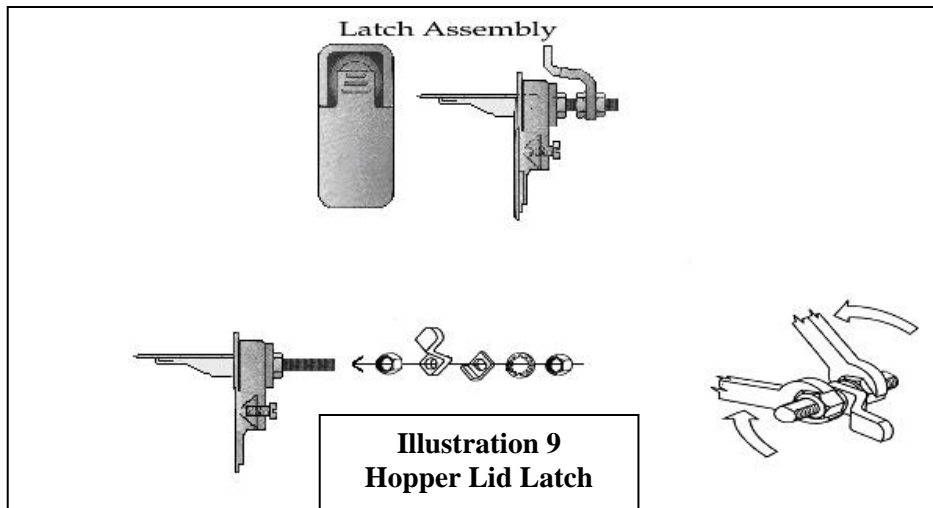

Important: Hopper Lid Latch must be checked periodically and kept tight so the top is sealed to prevent back-burn.

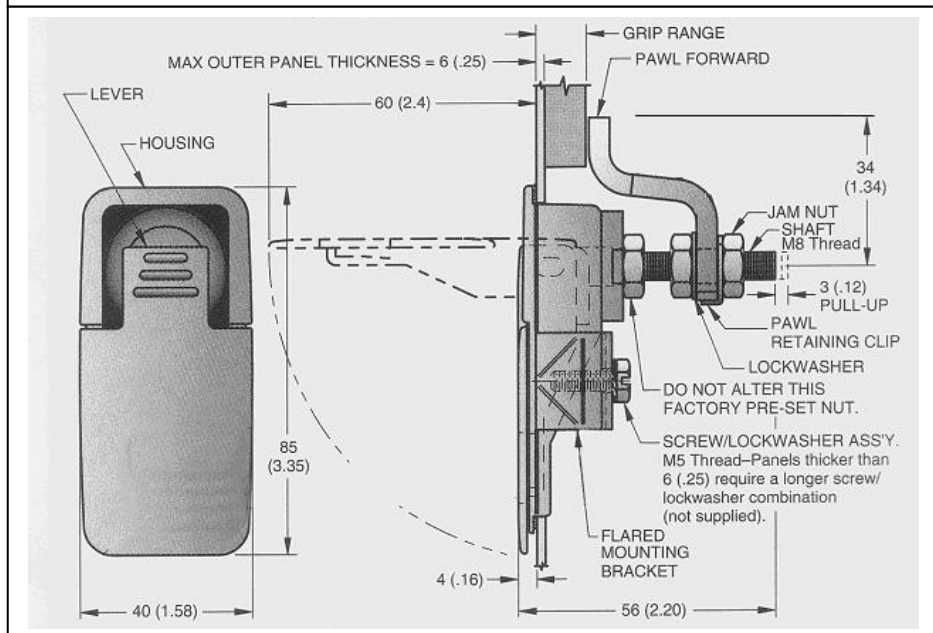

TROUBLE-SHOOTING GUIDE

WARNING: TO AVOID ELECTRICAL SHOCK ALWAYS *DISCONNECT* THE UNIT FROM THE POWER SOURCE BEFORE ATTEMPTING ANY REPAIR. IF THIS GUIDE DOES NOT CORRECT THE PROBLEM CALL YOUR LOCAL DEALER OR OUR TECHNICAL SUPPORT AT 1-800-245-6489.

<u>Problem</u>	<u>Cause</u>	<u>Solution</u>
1. Auger not turning	<ol style="list-style-type: none"> 1. Loose set screw 2. Bad gear motor 3. Foreign matter in auger 4. Vacuum sensor 	<ol style="list-style-type: none"> 1. Tighten setscrew on collar 2. Replace auger motor 3. Remove pellets and object 4. Check exhaust blower
2. Smoke smell or dust in house	<ol style="list-style-type: none"> 1. Improper exhaust connection 	<ol style="list-style-type: none"> 1. Check all connections for leaks especially the exhaust blower connection; Seal with silicone, hose clamp or aluminum tape.
3. Room air blower not operating	<ol style="list-style-type: none"> 1. Loose sensor 2. Bad blower 	<ol style="list-style-type: none"> 1. Tighten connection on sensor 2. Replace blower
4. Exhaust blower not operating	<ol style="list-style-type: none"> 1. Loose connection 2. Bad blower 	<ol style="list-style-type: none"> 1. Check connection at c/board 2. Replace blower
5. Lazy fire – Fire burns with a lazy, orange flame and/or fuel builds up in the Burnpot. Glass may become dirty.	<ol style="list-style-type: none"> 1. Control board settings 2. Bad exhaust blower 3. Excessive pellet moisture 4. Excessive ash 5. Low quality pellets 6. Flue or intake is restricted. 7. Glass door not shut and sealed tightly. 8. Ash removal plates are not pushed completely in. 9. Exhaust fan is not running or stove not venting properly. 10. Moisture content above 15%. 11. Blockage inside stove and exhaust pipes. 12. Feed rate is too high for fuel. 13. Inadequate combustion air available. 	<ol style="list-style-type: none"> 1. Review board settings 2. Replace blower 3. Keep pellets inside 4. Remove baffles; Clean unit 5. Use premium pellets 6. Inspect flue and intake for obstructions. 7. Adjust door handle or replace gasket if necessary. 8. Verify ash removal plates are pushed completely in. 9. Verify that exhaust fan is running and venting properly. If not, check connection and clean or replace. 10. Allow fuel to dry or mix with some wood pellets. 11. Check inside stove and exhaust pipes for blockage. Tap inside walls of Firebox, clean behind the lower access plates (located on the back inside wall, next to the Burnpot); clean Burnpot and Firebox vent holes above firebrick panel. 12. Reduce heat setting. 13. Outside combustion air is mandatory. (Our Part PU-OAK is acceptable).
6. Blown fuse (6 AMP)	<ol style="list-style-type: none"> 1. Power surge 2. Exposed wire 3. Electric motor shorting or bound up 	<ol style="list-style-type: none"> 1. Replace fuse; use surge protector 2. Check for exposed or frayed wire and loose connections 3. Check motors and blowers for obstructions or lock-up
7. High pellet consumption	<ol style="list-style-type: none"> 1. Low quality pellets 2. Board out of adjustment 	<ol style="list-style-type: none"> 1. Use premium fuel 2. Check control board settings
8. Squeaking noise	<ol style="list-style-type: none"> 1. Build up in tube 2. Blower noise 	<ol style="list-style-type: none"> 1. Remove auger and clean 2. Remove and oil blower
9. Pinging or rattling noise	<ol style="list-style-type: none"> 1. Foreign material 2. Loose set screw 	<ol style="list-style-type: none"> 1. Check blower for material 2. Check impeller blower screw

***Improper installation may cause a back draft.**

***NOTE:** Also check for loose or cracked vacuum hose on vacuum switches (see Parts Diagram).

NOTE: Negative pressure in a home is a serious issue.
This unit must be installed with the Outside Air Kit (Part PU-OAK).

CAUTION: UNPLUG THE UNIT PRIOR TO ANY SERVICE WORK!

TROUBLE-SHOOTING GUIDE

WARNING: TO AVOID ELECTRICAL SHOCK ALWAYS *DISCONNECT* THE UNIT FROM THE POWER SOURCE BEFORE ATTEMPTING ANY REPAIR. IF THIS GUIDE DOES NOT CORRECT THE PROBLEM CALL YOUR LOCAL DEALER OR OUR TECHNICAL SUPPORT AT 1-800-245-6489.

<u>Problem</u>	<u>Cause</u>	<u>Solution</u>
10. Unit shuts down in 20 to 30 minutes E2 error code	<ol style="list-style-type: none"> 1. Loose heat sensor 2. Control board settings 3. Failure to start 	<ol style="list-style-type: none"> 1. Check stove connection 2. Check settings; always start unit on "5" to "9" setting 3. Check igniter for buildup
11. Unit keeps shutting down ("E" codes on control board)	<ol style="list-style-type: none"> 1. Blocked flue (E-2) 2. Unit Overfired (E-3) 3. Improper installation* (E-2) 	<ol style="list-style-type: none"> 1. Check for flue blockage (nests, rodents, excess soot, etc.) 2. If you see the E-3 code displayed on your control board, you have overfired your unit. You must let the unit cool and clean the Firebox and Burnpot. Be sure to clean the orifices (holes in the Burnpot). You should not burn your unit on High (Heat Range 9) continuously when burning corn. After a couple of hours burning corn on high, set the heat range to 7 and the blower to 9. Running the unit on high when burning corn for long periods can damage the unit. 3. Check for loose flue/pipe connections. Also be sure to have proper Outside Air Hook-up.
12. Fire goes out and stove shuts down. Fuel may stop feeding.	<ol style="list-style-type: none"> 1. Stirrer gummed up – Burnpot plugged. 2. Hopper empty 3. Auger turning but fuel not feeding. 4. Auger jams. 5. Auger has come loose. 6. Hopper lid switch tripped. 7. Temperature sensor Hi-limit 8. Vacuum switch tripped. Caused by exhaust blower not running, or venting blocked. 9. Auger motor not operating. 	<ol style="list-style-type: none"> 1. Remove and clean Stirrer, dump ash pan and clean Burnpot. 2. Refill. 3. Improper air mixture can cause the unit to burn fuel faster than the auger is feeding. 4. Remove auger and clean. Auger jams can be a problem if poor quality fuel is used, or if excessive fines (sawdust, corn cobs, husks, etc.) are present in hopper. Auger jams are evidenced when the auger turns, but no fuel is delivered. 5. Check to see if auger motor is turning and auger is not. NOTE: Auger is held to the auger motor by a coupler that is fastened to the auger motor with a setscrew. If coupler is loose, remove the auger motor and tighten setscrew in the coupler. 6. Lid ajar or open; debris under hopper seal. 7. Evident when the unit is extremely hot. Reduce Heat Range by 1. 8. Check blower, clean or replace as necessary. Clean any blockage from venting. Too many elbows in the venting restrict air flow causing vacuum switch to open. 9. Inspect connection and replace if necessary.

*Improper installation may cause a back draft.

*NOTE: Also check for loose or cracked vacuum hose on vacuum switches (see Parts Diagram).

**NOTE: Negative pressure in a home is a serious issue.
This unit must be installed with the Outside Air Kit (Part PU-OAK).**

CAUTION: UNPLUG THE UNIT PRIOR TO ANY SERVICE WORK!



MODEL 10-CPM, 49-TRCPM, 49-SHCPM

MANUFACTURED DATE: [REDACTED]

SERIAL NO. WHI - [REDACTED]

PELLET FUEL ROOM HEATER, ALSO FOR USE IN MOBILE HOMES
TESTED TO UL 1482/ASTM E 1509/ULC S627
ELECT. RATING: 120V, 60HZ, 5,5A

PREVENT HOUSE FIRES

- INSTALL AND USE ONLY IN ACCORDANCE WITH THE OWNER'S MANUAL PROVIDED WITH THIS APPLIANCE.
- CONTACT LOCAL BUILDING OR FIRE OFFICIALS ABOUT RESTRICTIONS AND INSTALLATION INSPECTIONS IN YOUR AREA.
- FOR USE WITH WOOD PELLETS/CORN/CHERRY PITTS. ONLY.
- WOOD PELLETS MUST BE 1/4 INCH IN DIAMETER.
- DO NOT CONNECT THIS UNIT TO A CHIMNEY FLUE SERVING ANOTHER APPLIANCE.
- KEEP VIEWING AND ASH REMOVAL DOORS TIGHTLY CLOSED DURING OPERATION.
- INPUT RATING - PELLETS 4.5 LBS/HR.
- INPUT RATING - CORN 4.7 LBS/HR.
- INPUT RATING - CHERRY PITTS 3.5 LBS/HR.
- THIS UNIT MUST BE INSTALLED WITH TYPE L CORN VENT PIPE.
- MEETS EPA PARTICULATE MATTER REQUIREMENTS FOR WOOD HEATERS BUILT AFTER JULY 1, 1990

INSTALLATION REQUIREMENTS - REFER TO LOCAL CODES AND THE CHIMNEY MANUFACTURER'S INSTRUCTIONS FOR PRECAUTIONS REQUIRED FOR PASSING CHIMNEY THROUGH A COMBUSTIBLE WALL OR CEILING. PLACE ON NON-COMBUSTIBLE FLOOR PROTECTION WITH A MINIMUM R-VALUE OF X, WHICH EXTENDS 6-INCHES TO THE FRONT AND 6-INCHES TO EACH SIDE OF THE FUEL OPENING. SEE OWNER'S MANUAL FOR ADDITIONAL CLEARANCE INFORMATION.

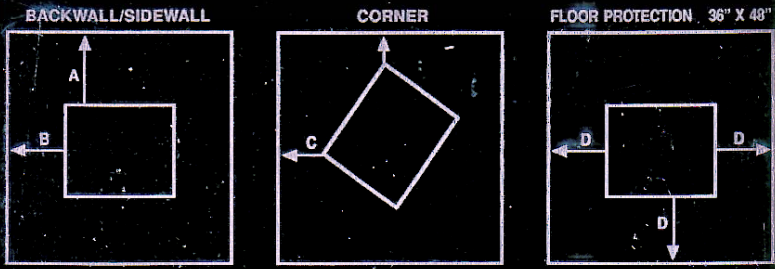

A = 3 INCHES (76.2 MM) B = 6 INCHES (152.4 MM)
 C = 4.5 INCHES (114.3 MM) D = 6 INCHES (152.4 MM)
 ALCOVE = 6" TO SIDE WALL, 6" TO BACK WALL, 66" MINIMUM FLOOR TO CEILING.

CAUTION - OPERATE THIS UNIT ONLY WITH THE FUEL HOPPER LID CLOSED. FAILURE TO DO SO MAY RESULT IN EMISSION OF PRODUCTS OF COMBUSTION FROM THE HOPPER UNDER CERTAIN CONDITIONS. MAINTAIN HOPPER SEAL IN GOOD CONDITION. DO NOT OVERFILL THE HOPPER.



CAUTION: HOT WHILE IN OPERATION. DO NOT TOUCH. KEEP CHILDREN, CLOTHING, AND FURNITURE AWAY. CONTACT MAY CAUSE SKIN BURNS. SEE NAMEPLATE AND INSTRUCTIONS.

MANUFACTURED BY: ENGLAND STOVE WORKS P.O. BOX 206 MONROE, VA 24574

You may write your unit's Manufacture Date and Serial Number in the blank spaces on this sample tag, for future reference. This sample tag also shows the safety info. such as UL testing standard, etc. for your local officials, or anyone else who may need reference information.

Have this information on hand if you phone the factory or your dealer regarding this product.

Retain for your files:

Model Number _____

Date of Purchase _____

Date of Manufacture _____ Serial # _____

LIMITED 5 YEAR WARRANTY FROM THE DATE OF PURCHASE TO THE ORIGINAL OWNER

The manufacturer extends the following warranties:

Five Year Period:

1. Carbon steel and welded seams in the Firebox are covered for 5 years against splitting.
2. The cast iron door and hinges are covered for 5 years against cracking.

One Year Period:

3. Component parts such as the hopper, auger, Burnpot, baffle plate, auger shafts and/or couplers, auger bearings, and fasteners are covered for 1 year against cracking, breakage and welded seams from separating.
4. Electrical components, brick fiber board, accessory items, glass and the painted surface are covered for 1 year from the date of purchase.

Conditions and Exclusions:

Damage from over-firing will void your warranty.

This warranty does not apply if damage occurs because of an accident, improper handling, improper installation, improper operation, abuse, or unauthorized repair made or attempted to be made.

The manufacturer is not liable for indirect, incidental, or consequential damages in connection with the product including any cost or expense providing substitute equipment or service during periods of malfunction or nonuse.

All liability for any consequential damage for breach of any written or implied warranty is disclaimed and excluded. Some states do not allow the exclusion or limitations of incidental or consequential damages, so the above may not apply to you.

Procedure:

Purchaser must give notice of claim of defect within the warranty period and pay transportation to and from a service center designated by the factory. The dealer from which the unit was purchased or the factory, at our option, will perform the warranty service.

Other Rights:

This warranty gives you specific legal rights, and you may also have other rights, which may vary from state to state.

NOTE: THIS WARRANTY IS NULL AND VOID IF YOU DO NOT RETURN THE ATTACHED WARRANTY REGISTRATION WITH A COPY OF THE SALES RECEIPT WITHIN 30 DAYS FROM THE DATE OF PURCHASE.

WARRANTY IS NOT TRANSFERABLE

WARRANTY REGISTRATION for England's Stove Works

Purchased by (Name) _____

Address _____

City _____ State _____ Zip _____

Telephone _____

Email Address _____

DEALER INFORMATION

Purchased From (Dealer) _____

Address _____

City _____ State _____ Zip _____

UNIT INFORMATION

(Please be sure to refer to label on stove or sale receipt to complete this section)

Model Number _____ Purchase Date _____

Purchase Price _____

Serial Number _____ Mfg. Date _____

How did you first hear about our product? (Please check one)

Friend/Family Burn Trailer Demonstration Internet

Other: _____

Where did you receive information about our product? (Please check one)

Rec'd. info. via phone Dealer (Name of dealer): _____

Internet Other: _____

IMPORTANT NOTICE

**THIS REGISTRATION INFORMATION MUST BE ON FILE FOR THIS WARRANTY TO BE VALID.
PLEASE MAIL THIS INFORMATION WITHIN THIRTY (30) DAYS FROM THE DATE OF PURCHASE.**

Mail To:

England's Stove Works, Inc.
Technical Support Department
P.O. Box 206
Monroe, VA 24574

Or, Fax To:

(434) 929-4810 – 24 hours a day

Or, now available – Go online to complete your Warranty Registration!

Visit www.englishstoves.com if you prefer to register online.